

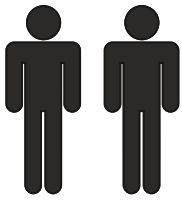

# AKCENT - AK-02 - KOMODA 2D

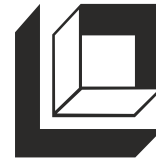

40 min.



**KIELECKA  
FABRYKA  
MEBLI**

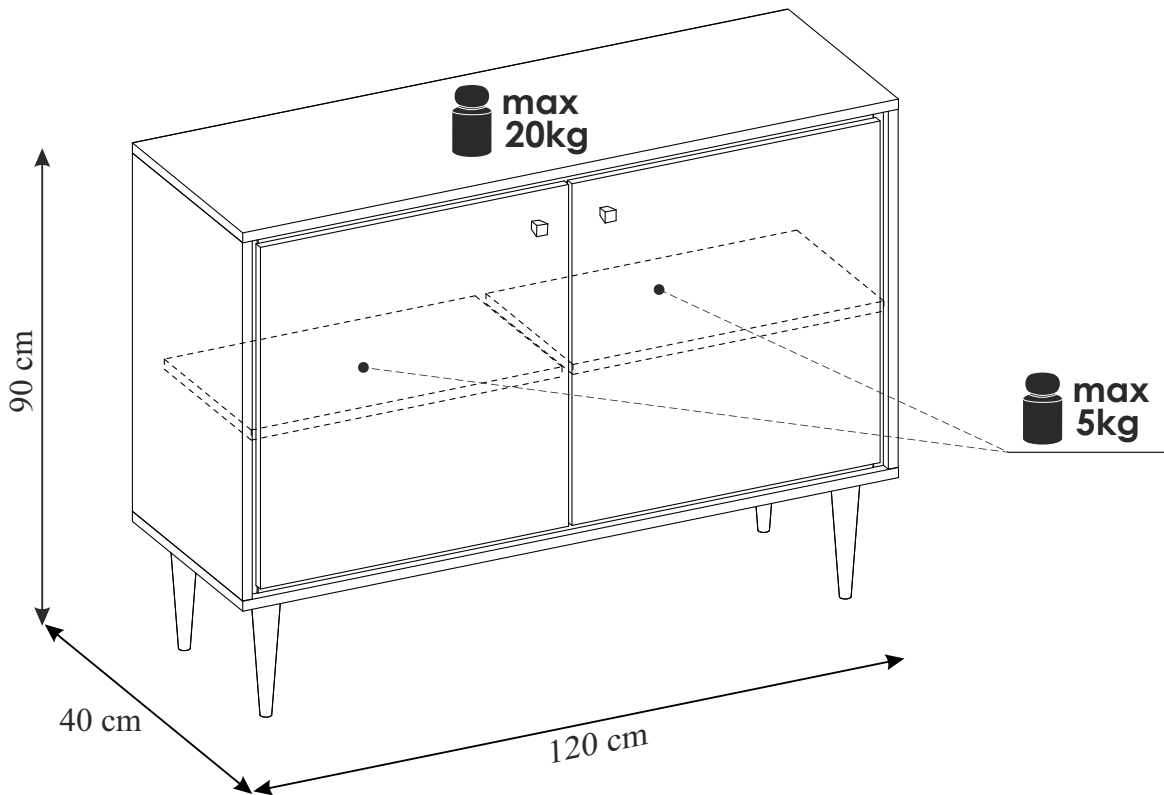

**Przed przystąpieniem do montażu należy sprawdzić zawartość paczek pod względem ilości i jakości z instrukcją montażu.**

**NIE WOLNO montować uszkodzonych elementów mebli, ewentualne ich wady należy zgłosić przed montażem w przeciwnym razie nie będą one podlegać reklamacji.**

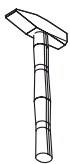
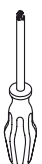
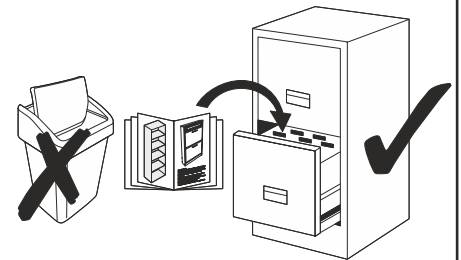

tel. 41 331 63 40,

fax.41 331 64 11

e-mail:biuro@k-f-m.pl

<http://www.kieleckafabrykamebli.pl/>

# AKCENT - AK-02 - KOMODA 2D

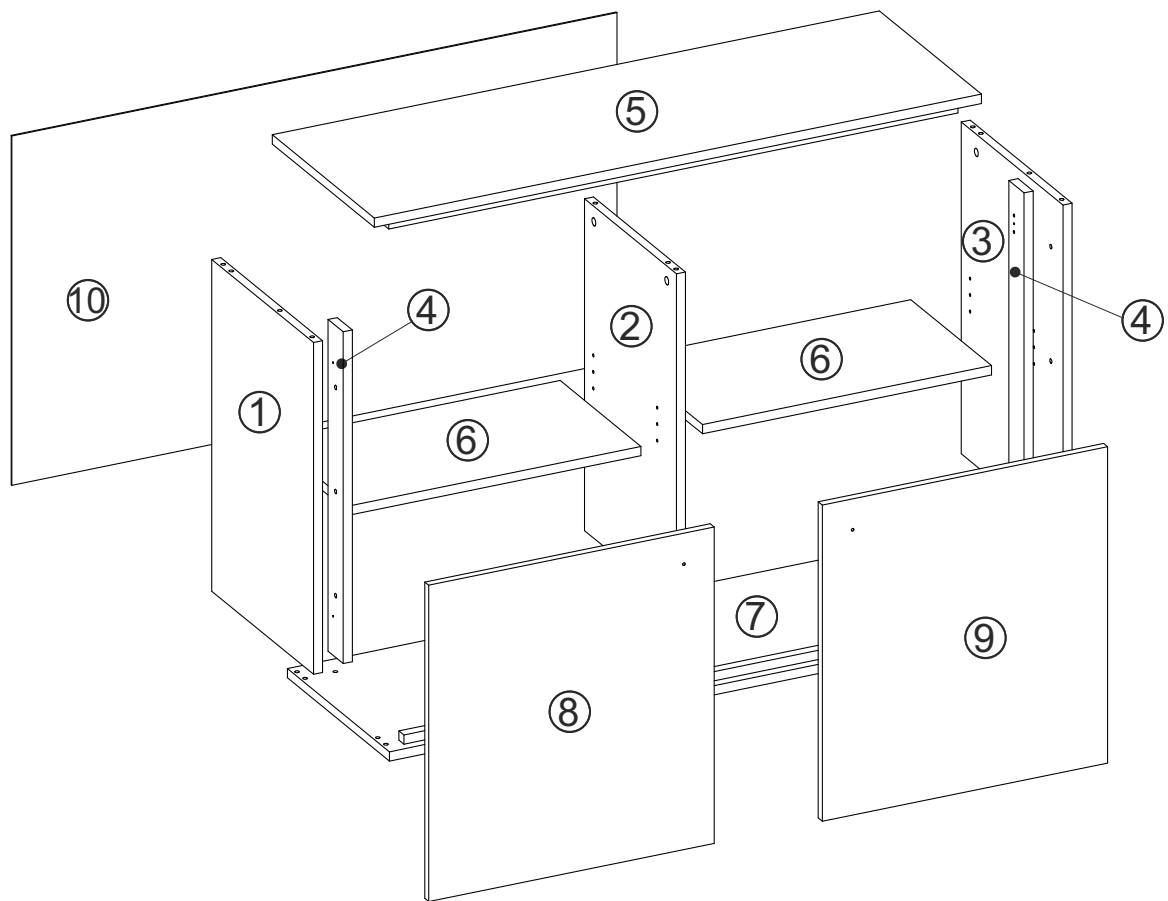

















	Kod	Wymiar	Szt.
①	AK02-01	644x403x18	1
②	AK02-02	644x364x18	1
③	AK02-03	644x403x18	1
④	AK02-04	644x60x18	2
⑤	AK02-05	1202x404x36	1
⑥	AK02-06	572x320x18	2
⑦	AK02-07	1202x404x36	1
⑧	AK02-08	614x565x18	1
⑨	AK02-09	614x565x18	1
⑩	AK02-10	678x1198x3	1



**Uwaga**  
Instrukcja montażu nie jest dokumentacją techniczną,  
producent zastrzega sobie możliwość zmian konstrukcyjnych.

# AKCENT - AK-02 - KOMODA 2D

<p>(a1) x10</p>  <p>ø 8x30</p>	<p>(a2) x6</p>  <p>ø 8x25</p>	<p>(b3) x4</p>  <p>H0</p>	<p>(b3) x4</p> 
<p>(d1) x8</p> 	<p>(e1) x6</p> 	<p>(e4) x10</p>  <p>ø 20</p>	<p>(f1) x6</p> 
<p>(g1) x6</p>  <p>ø 7x50</p>	<p>(h1) x2</p> 	<p>(k3) x2</p> 	<p>(k9) x4</p>  <p>ø 8x40</p>
<p>(m) x1</p> 	<p>(n1) x12</p>  <p>ø 3,5x16</p>	<p>(n4) x50</p> 	<p>(n5) x6</p>  <p>ø 4x30</p>
<p>(o6) x4</p> 			

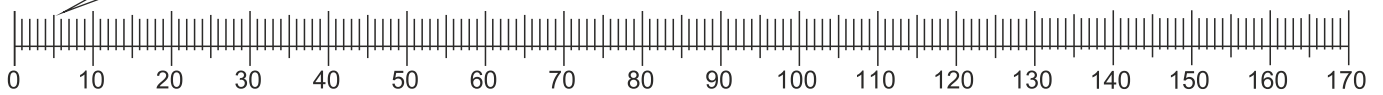
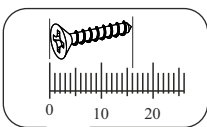

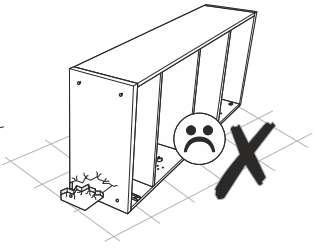
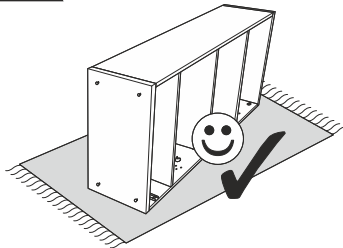
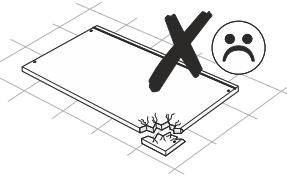
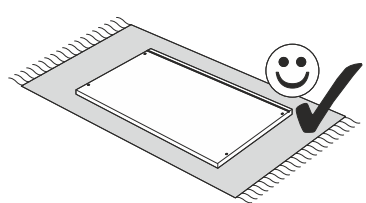

1



Zwróć szczególną uwagę na prawidłowy otwór podczas wbijania kołków

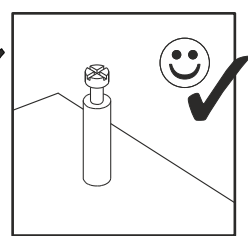
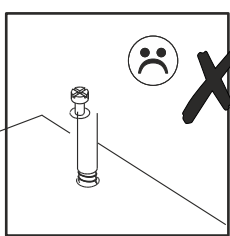
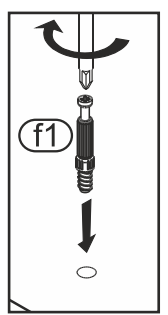
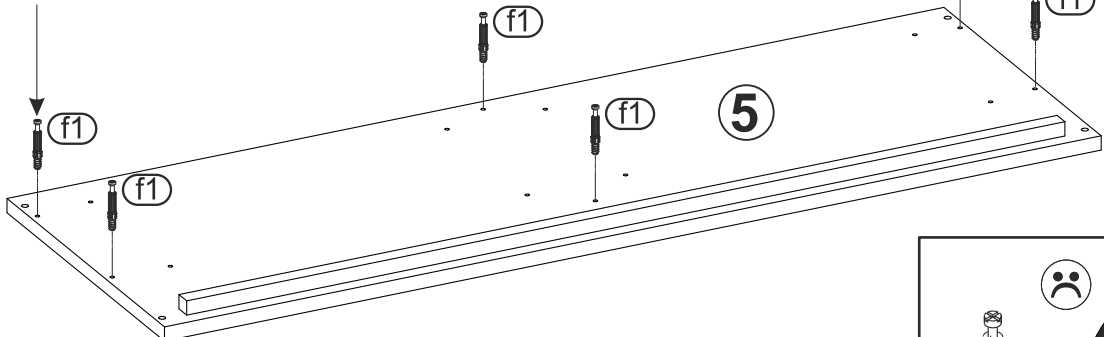
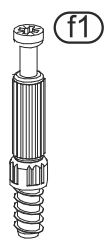
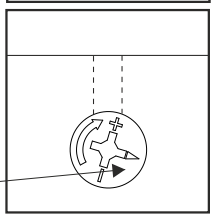
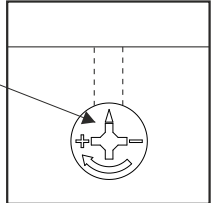
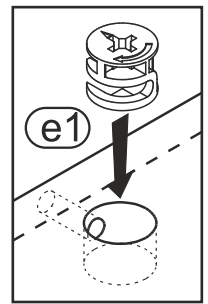
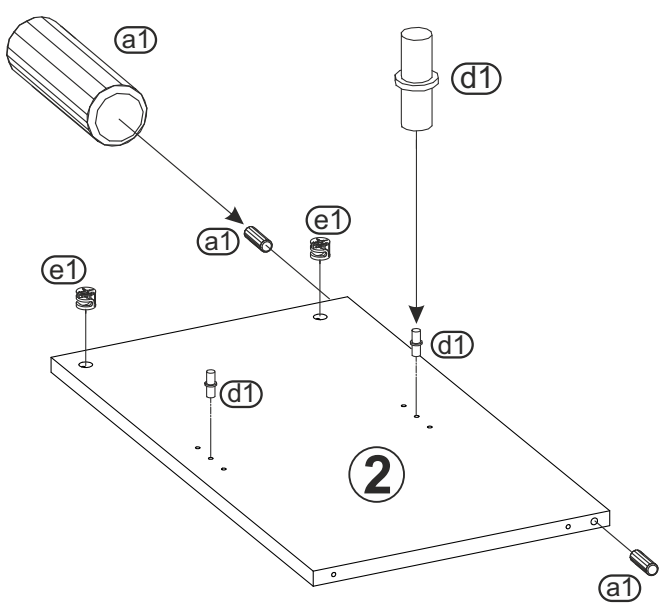
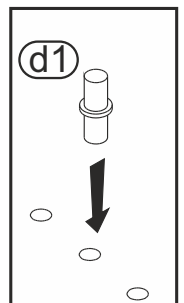
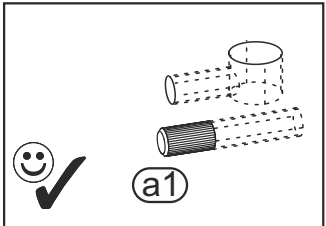
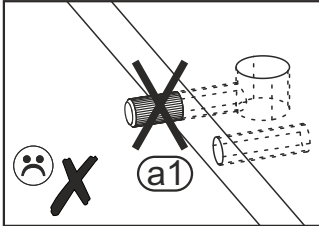
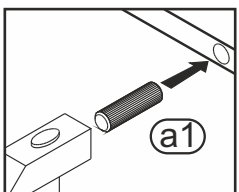

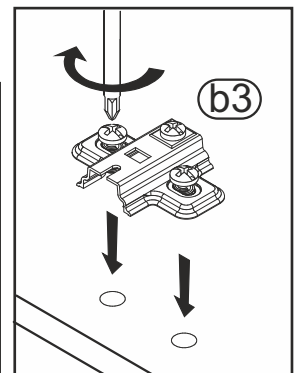
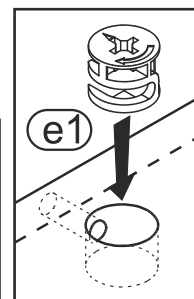
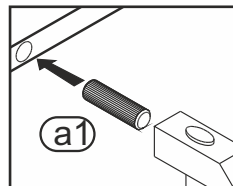
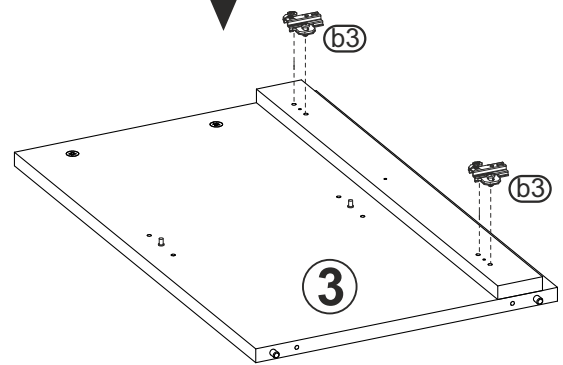
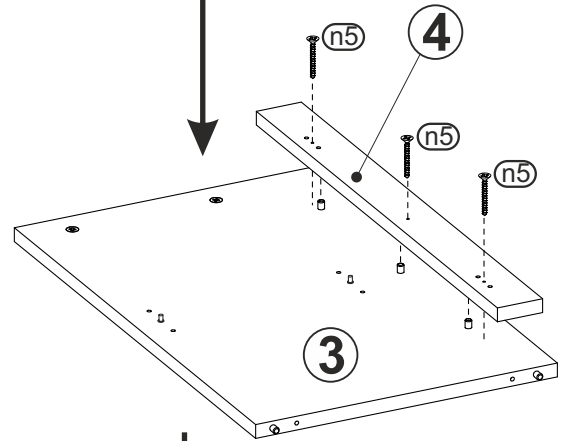
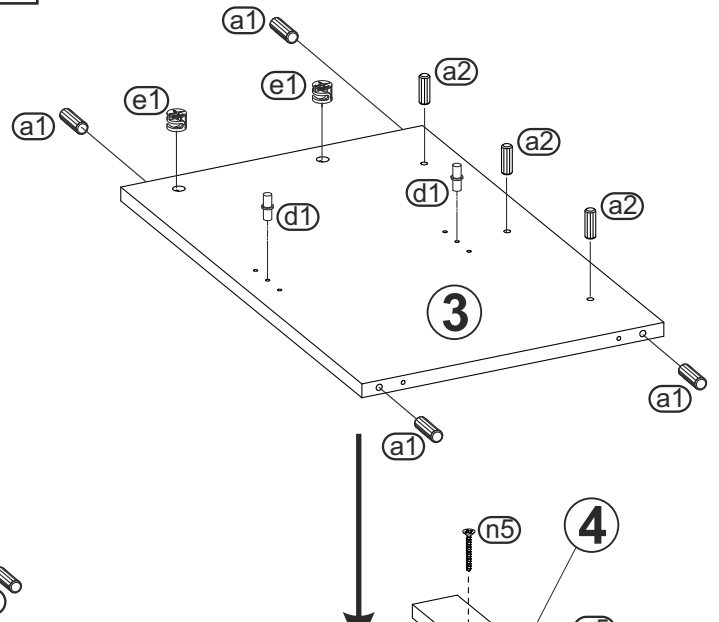
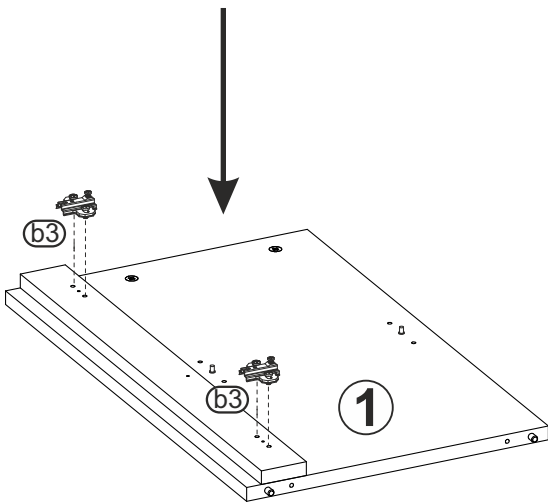
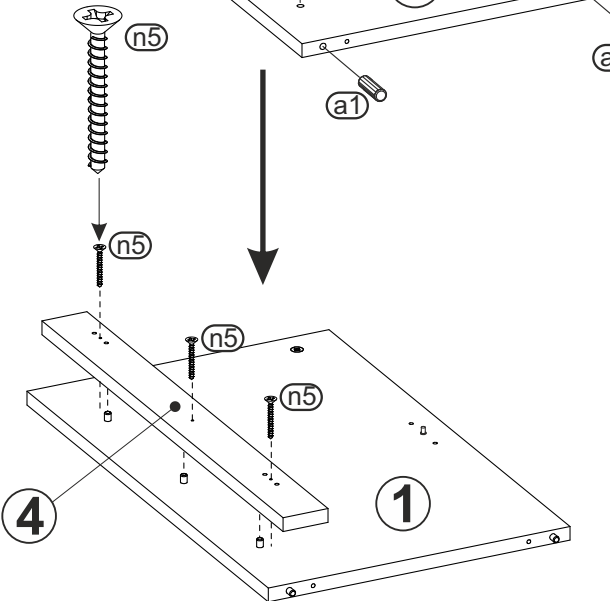
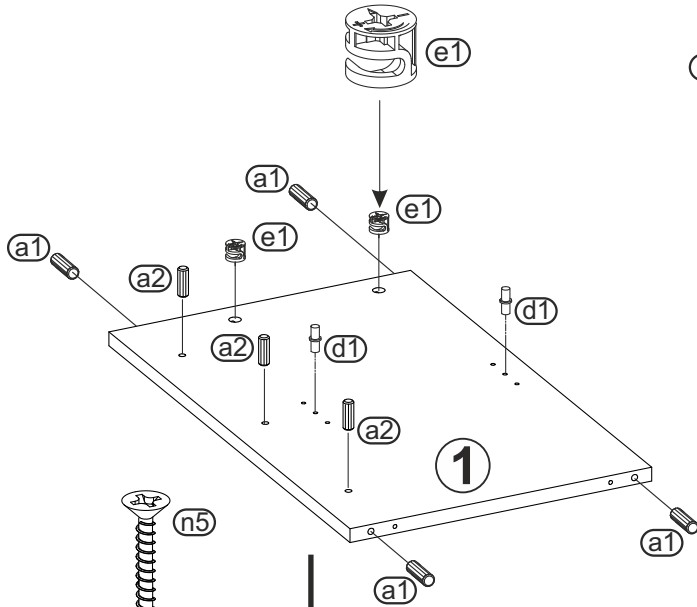
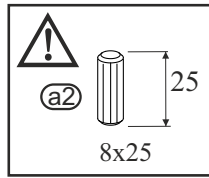
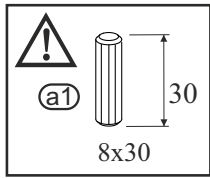

4

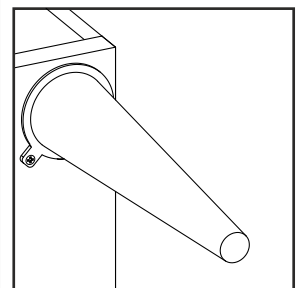
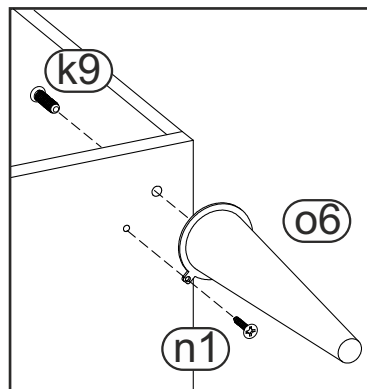
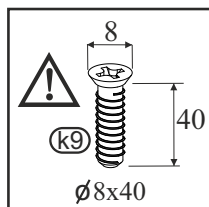
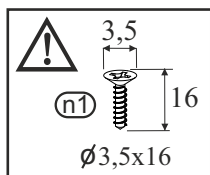
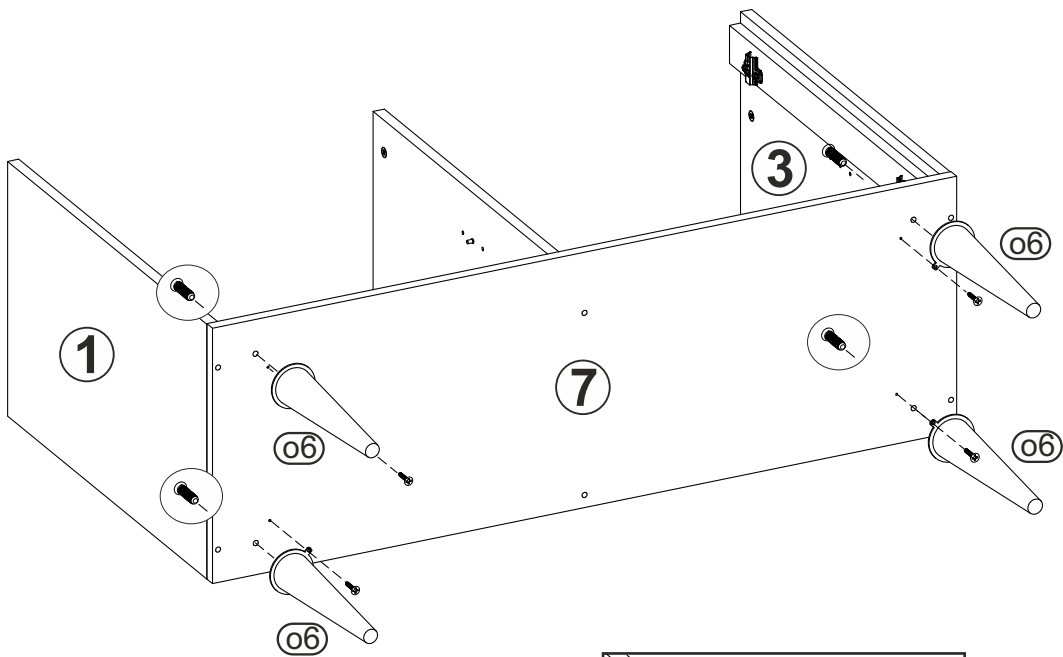
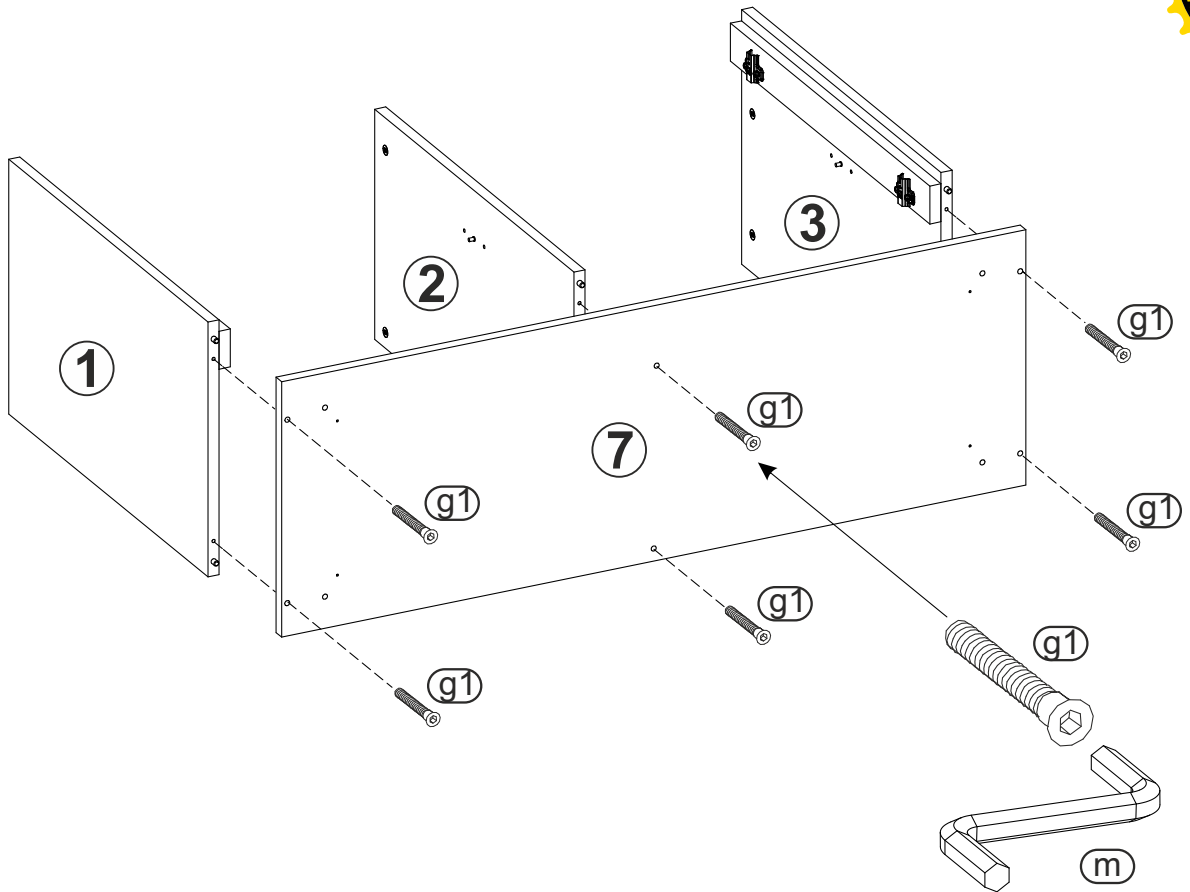

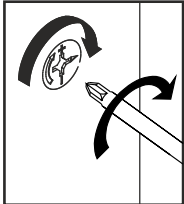
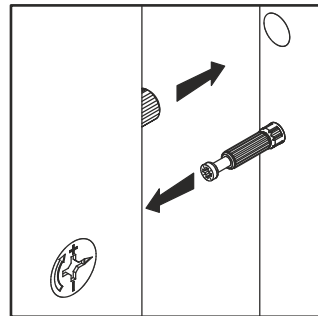
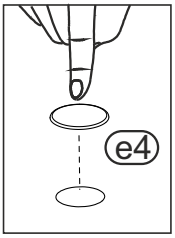
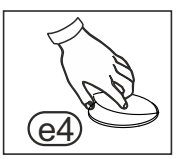
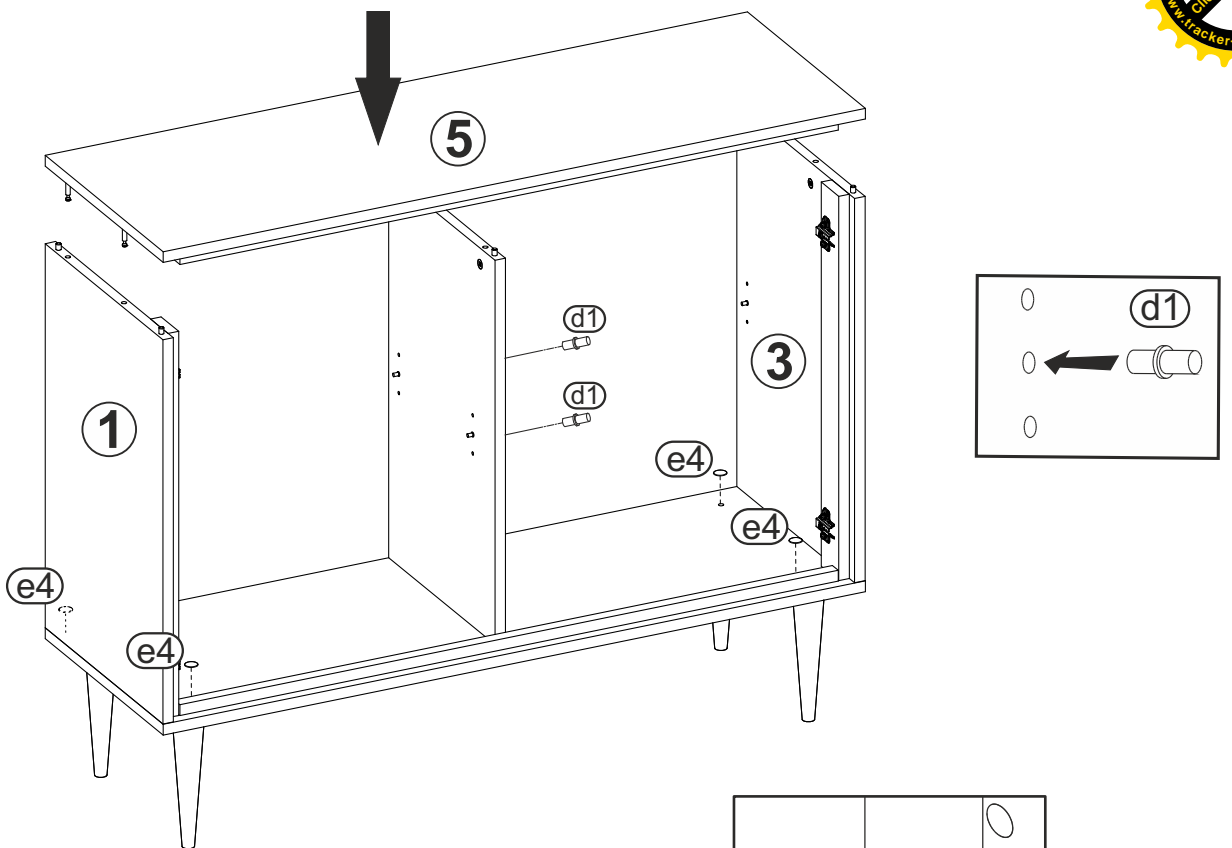

# 6

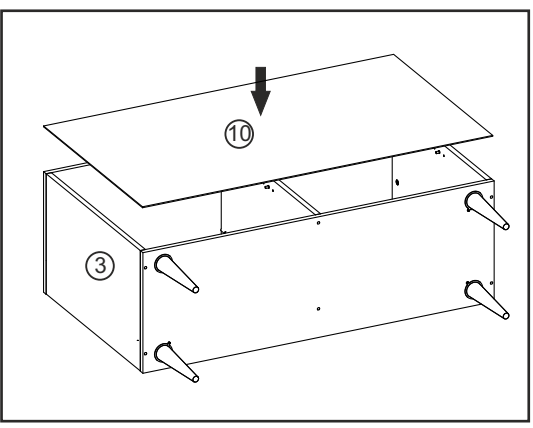

A=B

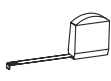

**UWAGA !!!**

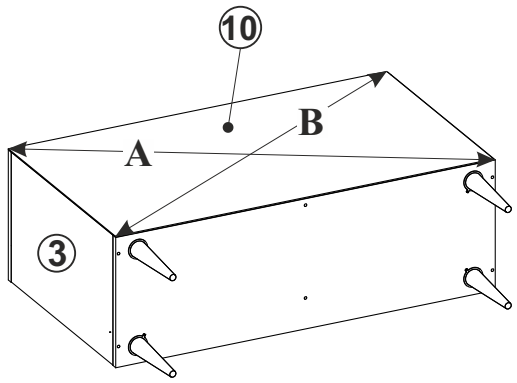

Uwaga !!!

Przed zamocowaniem ściany tylnej należy zmierzyć przekątne szafki. Jeżeli wymiary są jednakowe to możemy przystąpić do zamocowania jej, jeżeli nie to musimy do tego doprowadzić ściskając przeciwległe rogi szafki, tam gdzie wymiar był większy.

# Nieprawidłowe ustawienie przekątnych przed montażem ściany tylnej uniemożliwi prawidłowe późniejsze wyregulowanie frontów.

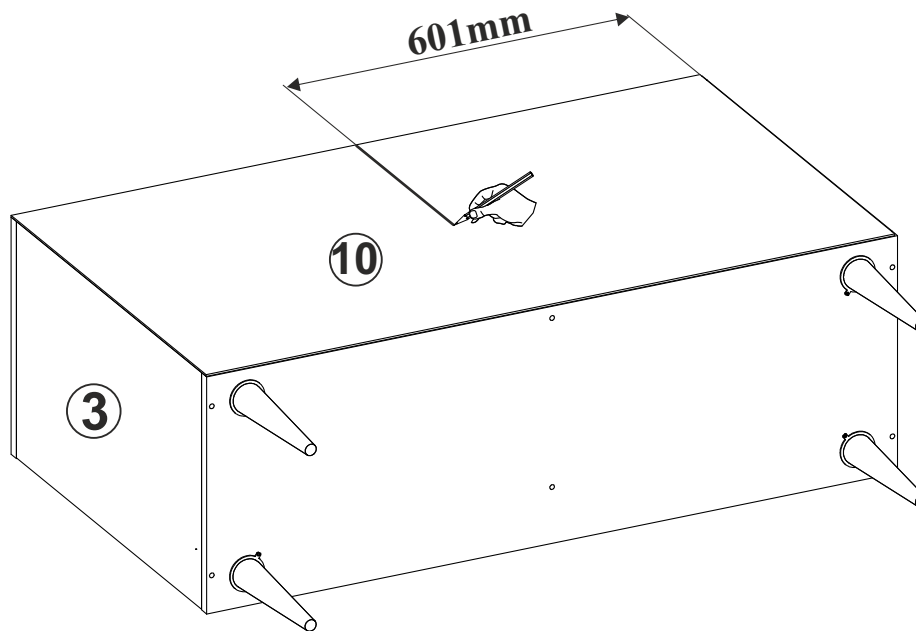
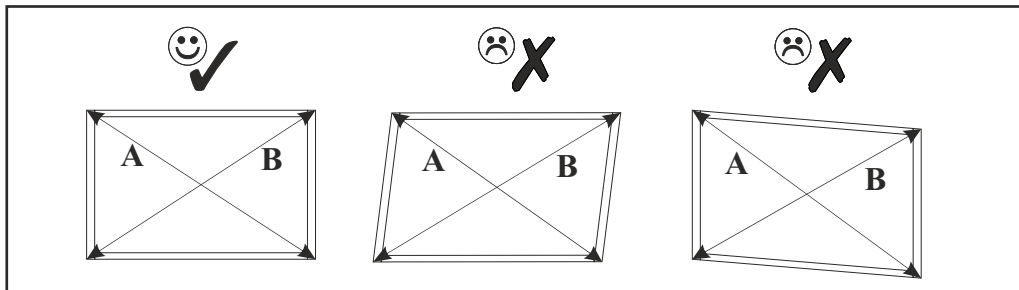



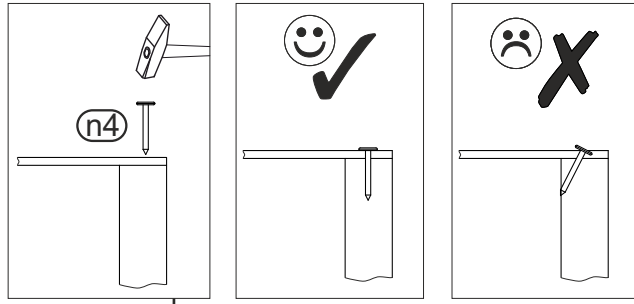

x50

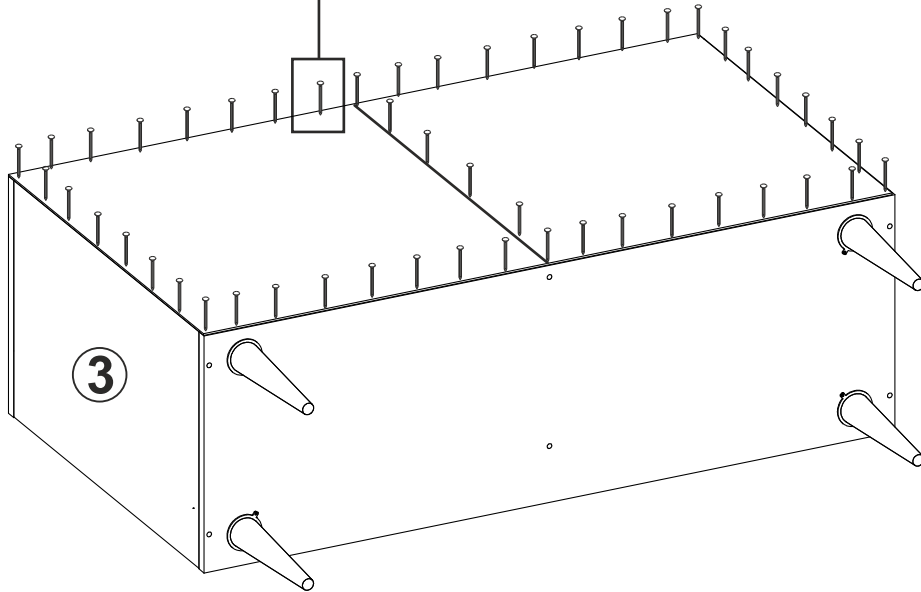

9

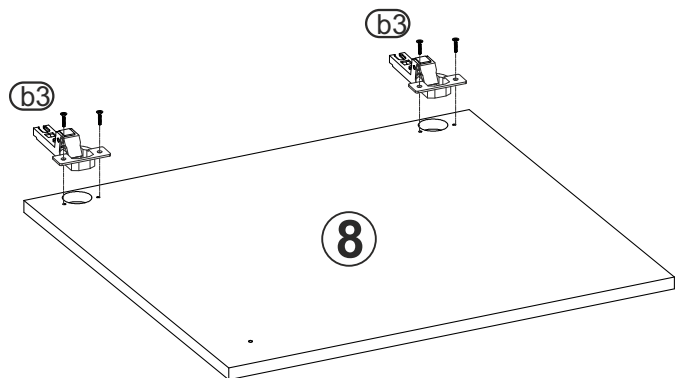
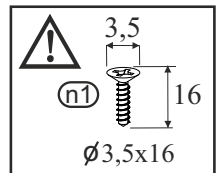
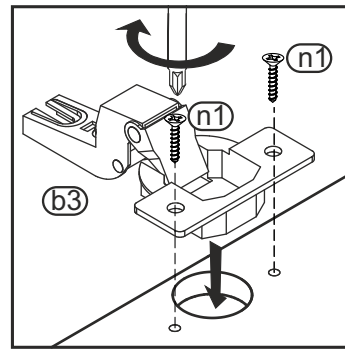
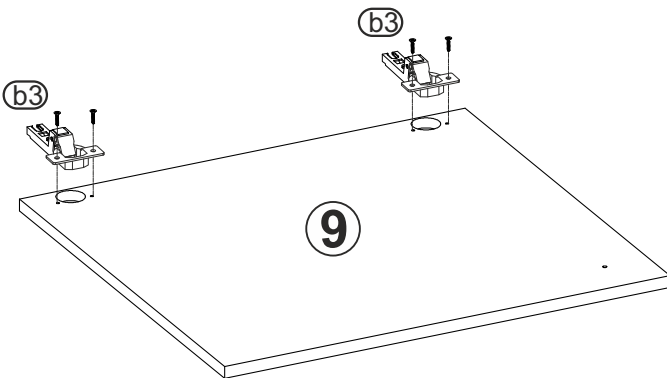

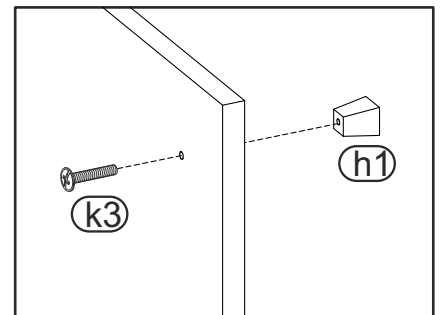
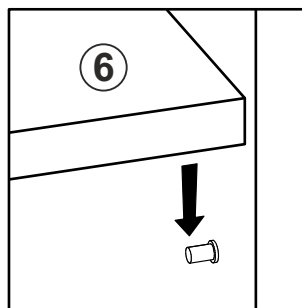
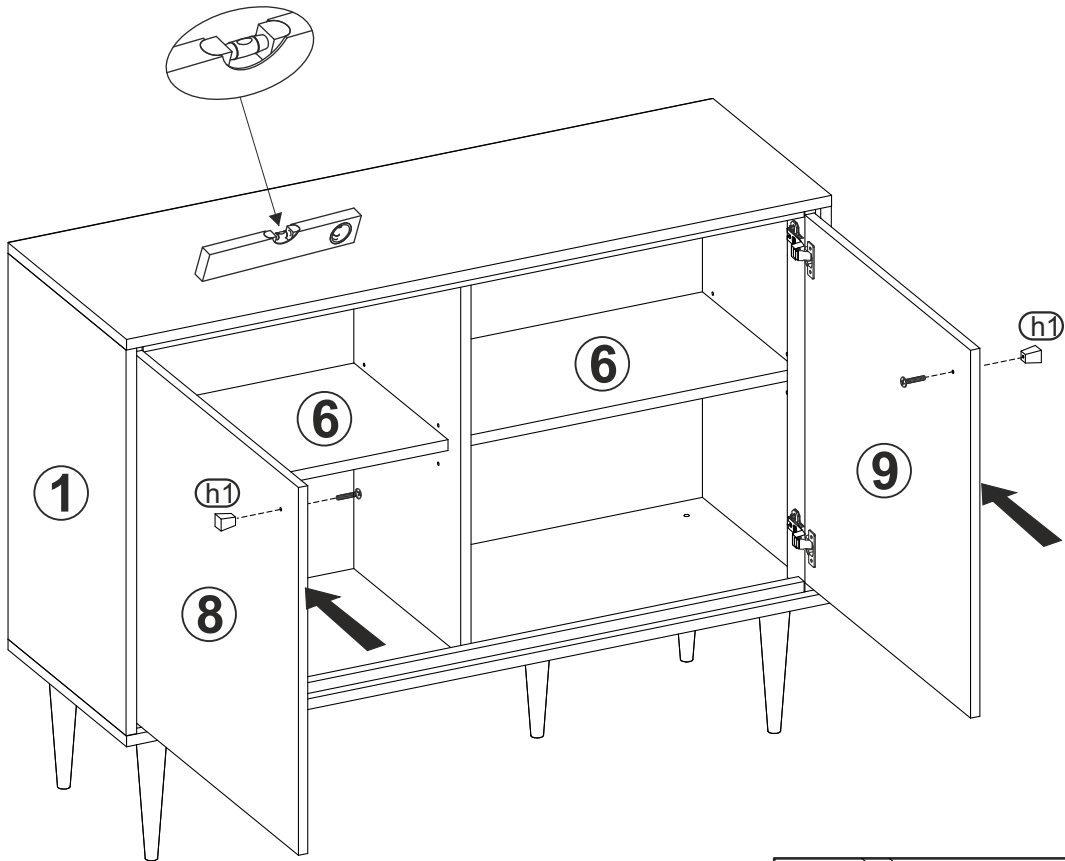
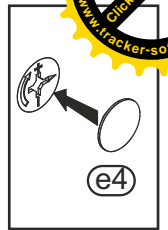
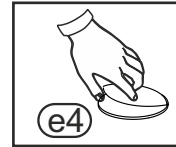
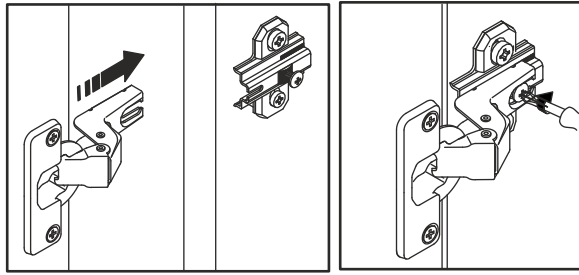

### Uwaga !!!

Wykonaj końcową regulację frontów.

