

ALA - A-31 - BIURKO 2S

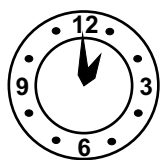

40 min.

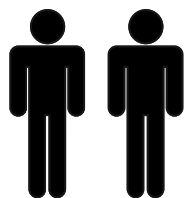
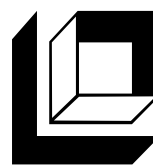

**KIELECKA
FABRYKA
MEBLI**

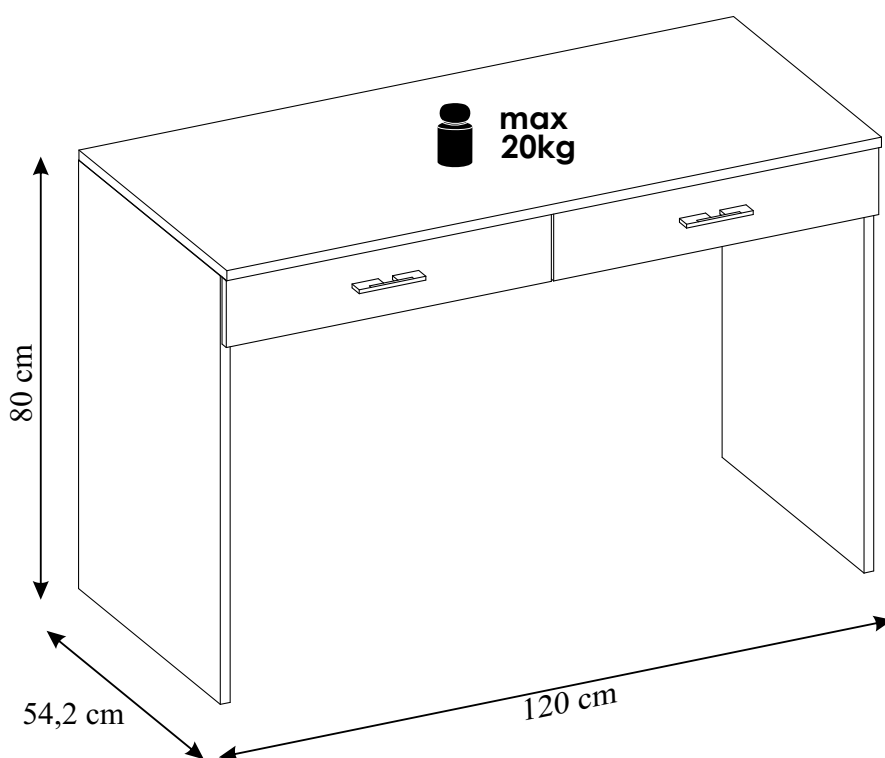

Przed przystąpieniem do montażu należy sprawdzić zawartość paczek pod względem ilości i jakości z instrukcją montażu.

NIE WOLNO montować uszkodzonych elementów mebli, ewentualne ich wady należy zgłosić przed montażem w przeciwnym razie nie będą one podlegać reklamacji.

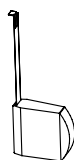
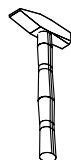
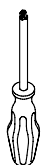
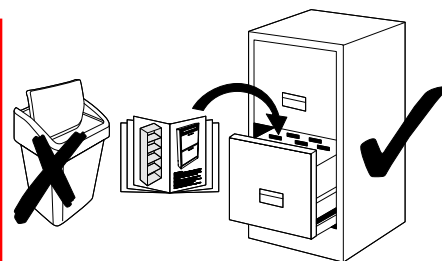

tel. 41 331 63 40,

fax.41 331 64 11

e-mail:biuro@k-f-m.pl

<http://www.kieleckafabrykamebli.pl/>

ALA - A-31 - BIURKO 2S

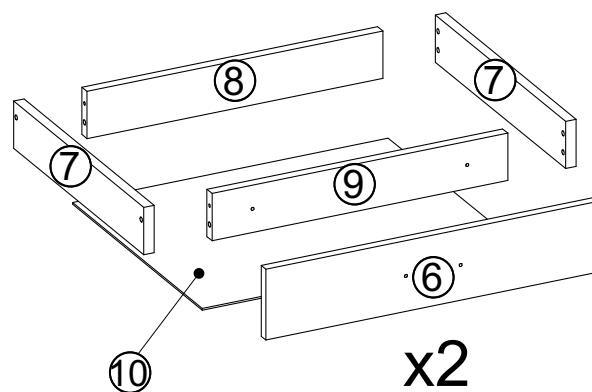
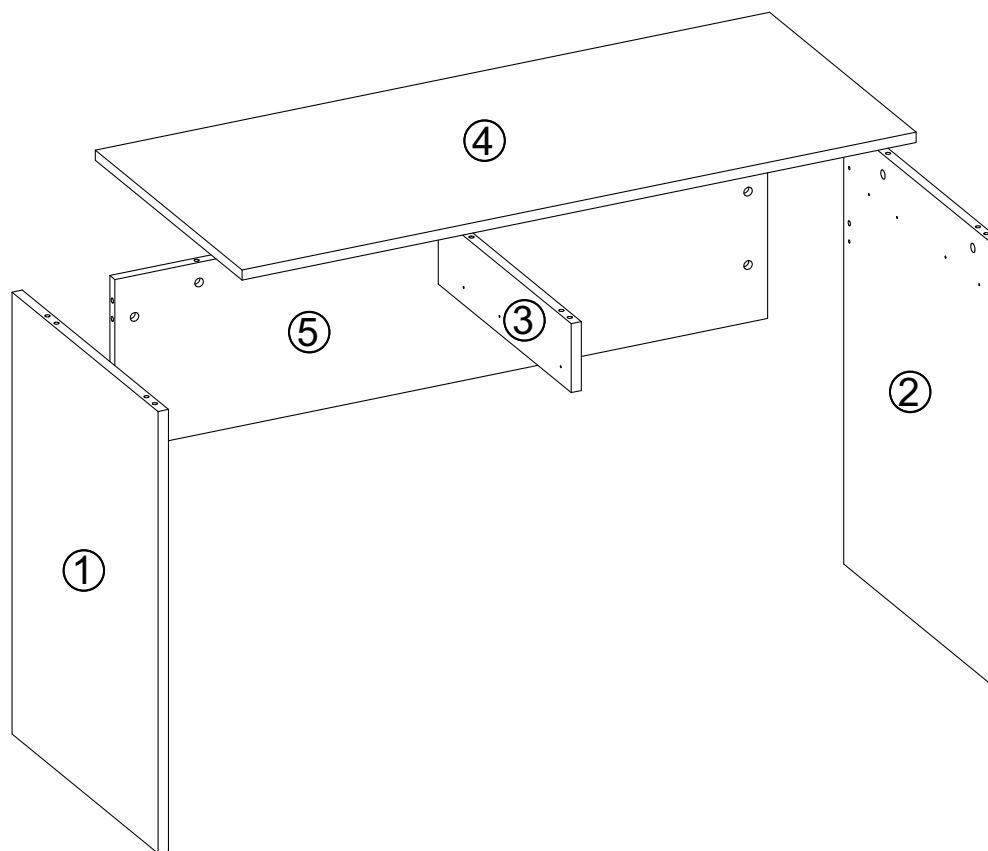













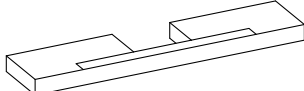

	Kod	Wymiar	Szt.
①	A31-01	770x520x18	1
②	A31-02	770x520x18	1
③	A31-03	120x482x18	1
④	A31-04	1200x542x18	1
⑤	A31-05	1162x300x18	1
⑥	A31-06	120x596x18	2
⑦	A31-07	450x80x18	4
⑧	A31-08	511x80x18	2
⑨	A31-09	511x80x18	2
⑩	A31-10	448x545x3	2

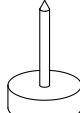

Uwaga
Instrukcja montażu nie jest dokumentacją techniczną,
producent zastrzega sobie możliwość zmian konstrukcyjnych.

ALA - A-31 - BIURKO 2S

<p>(a1) x19</p>  <p>∅ 8x30</p>	<p>(e1) x12</p> 	<p>(e4) x2</p>  <p>∅ 20</p>	<p>(e5) x5</p>  <p>∅ 13</p>
<p>(f1) x12</p> 	<p>(g1) x9</p>  <p>∅ 7x50</p>	<p>(h1) x2</p> 	<p>(k3) x4</p>  <p>∅ 4x45</p>
<p>(k4) x4</p>  <p>∅ 4x25</p>	<p>(m) x1</p> 	<p>(n1) x24</p>  <p>∅ 3,5x16</p>	<p>(n4) x28</p> 
<p>(o3) x4</p> 	<p>(o8) x4</p> 	<p>(p2) x2</p>  <p>L-450</p>	

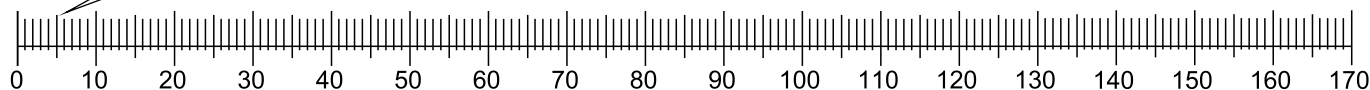
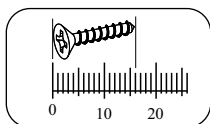

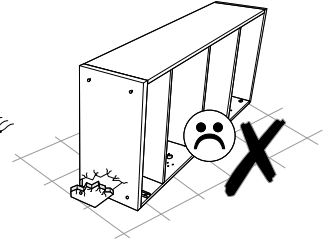
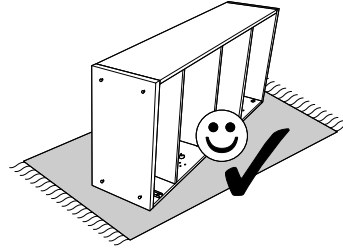
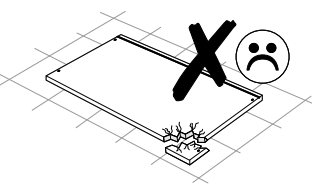
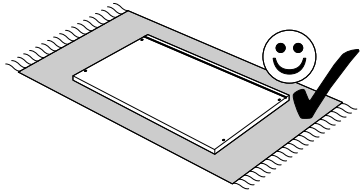

1



Zwróć szczególną uwagę na prawidłowy otwór podczas wbijania kołków

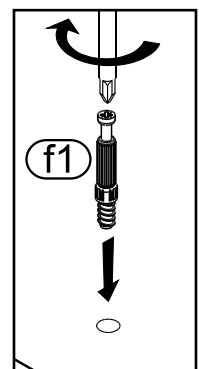
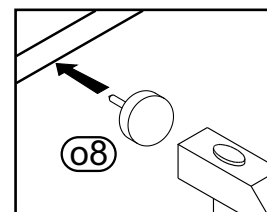
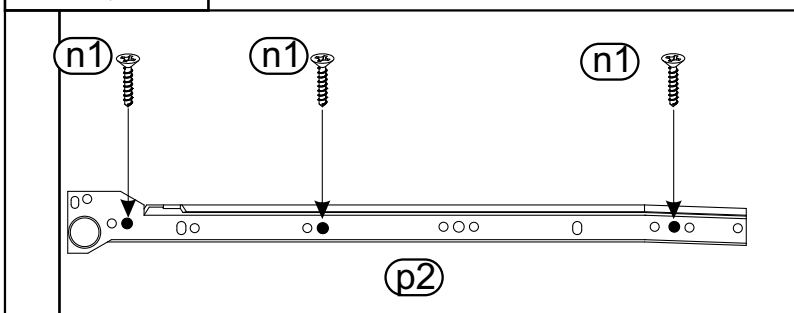
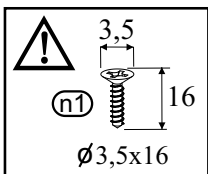
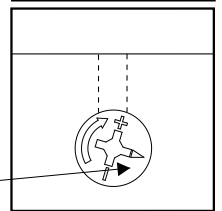
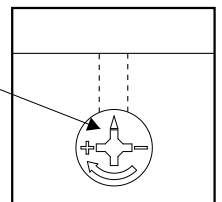
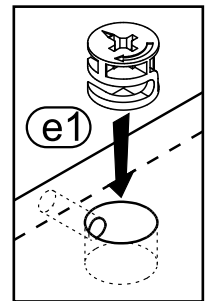
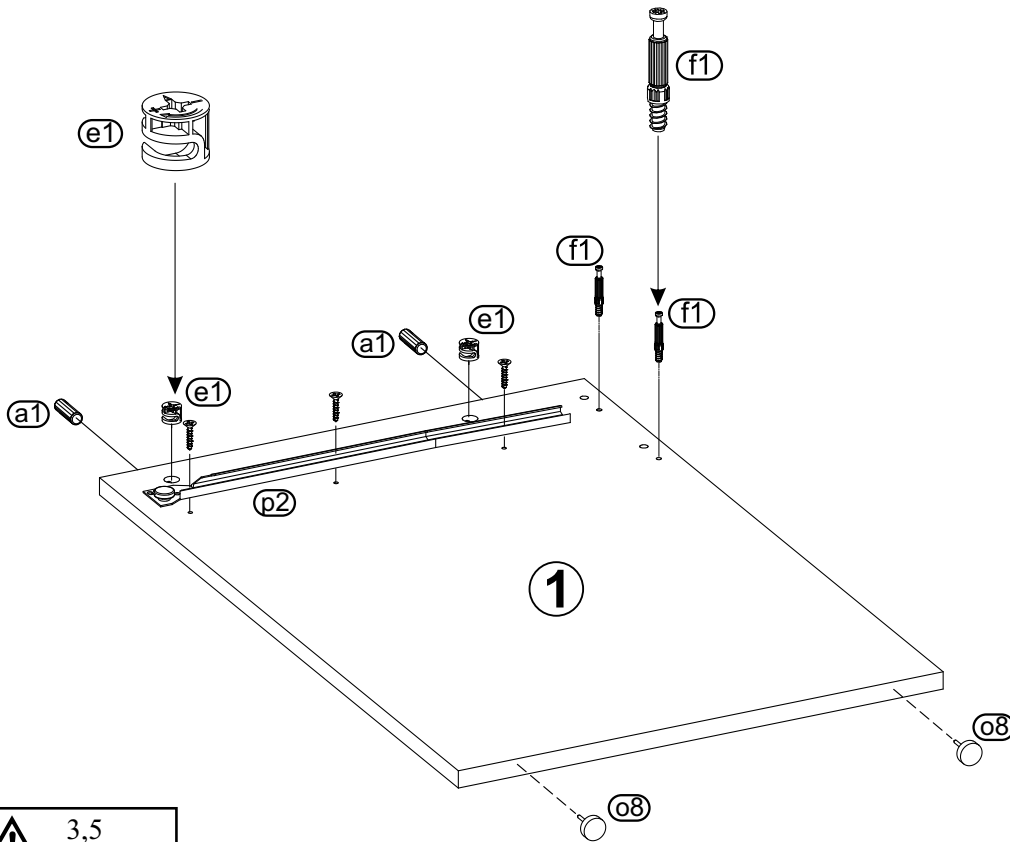
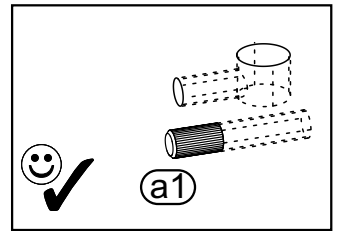
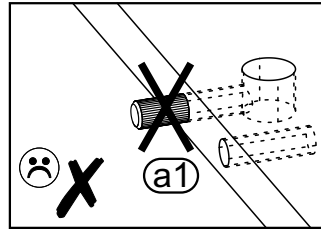
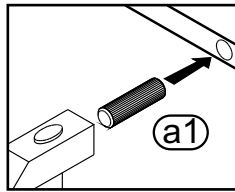

2

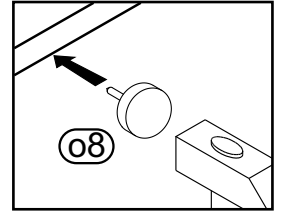
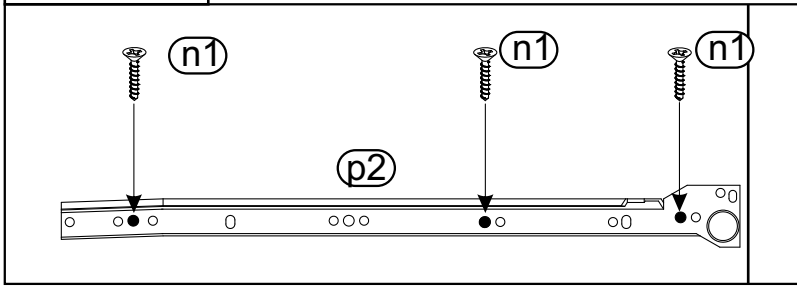
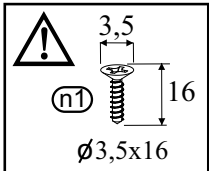
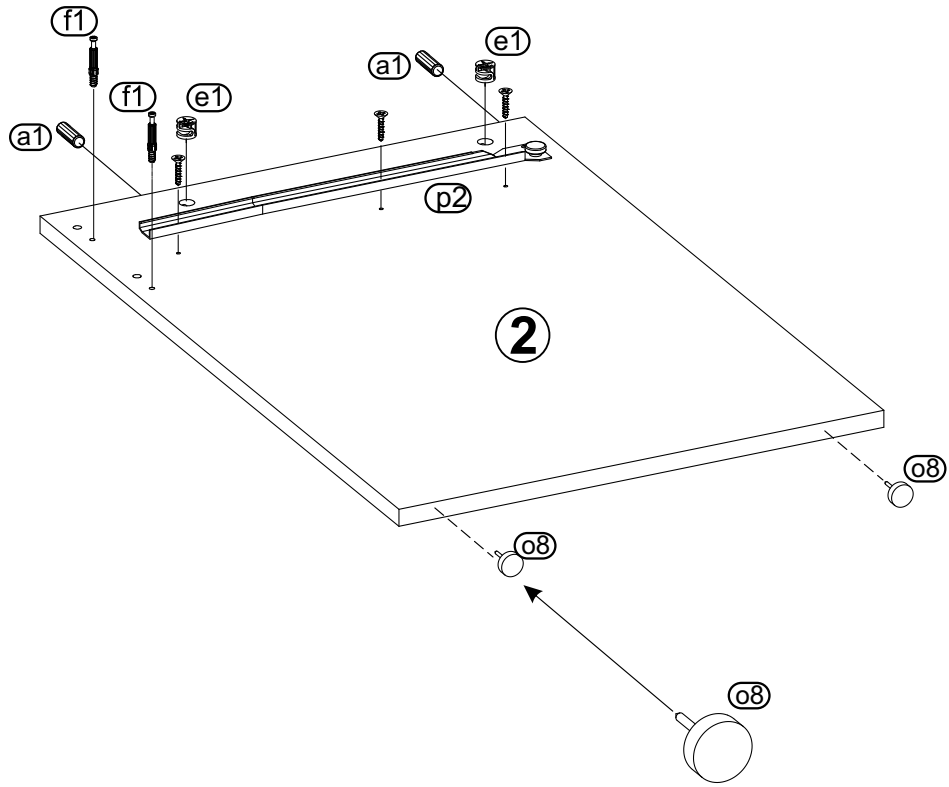

3

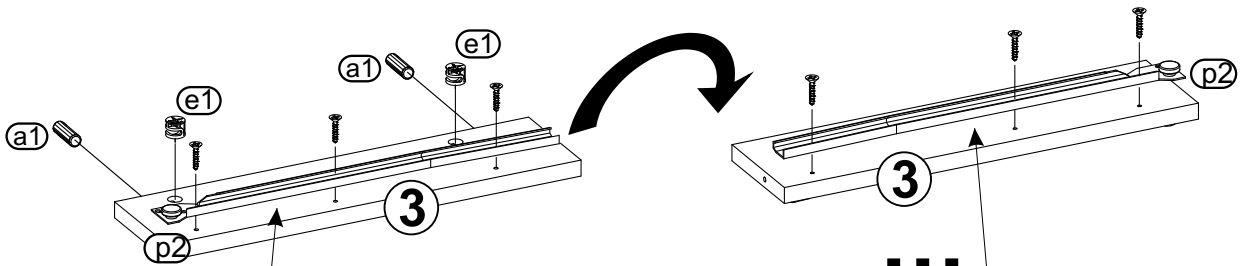

!!!

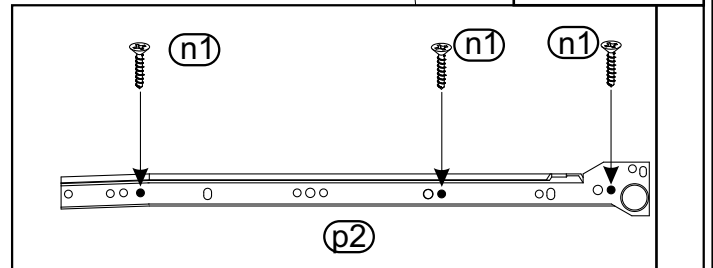
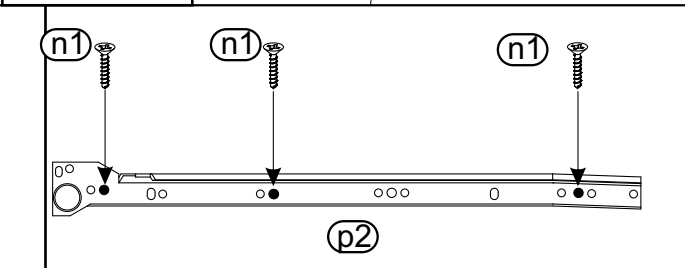
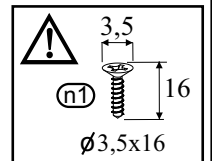
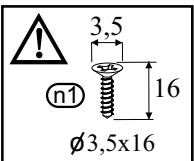

4

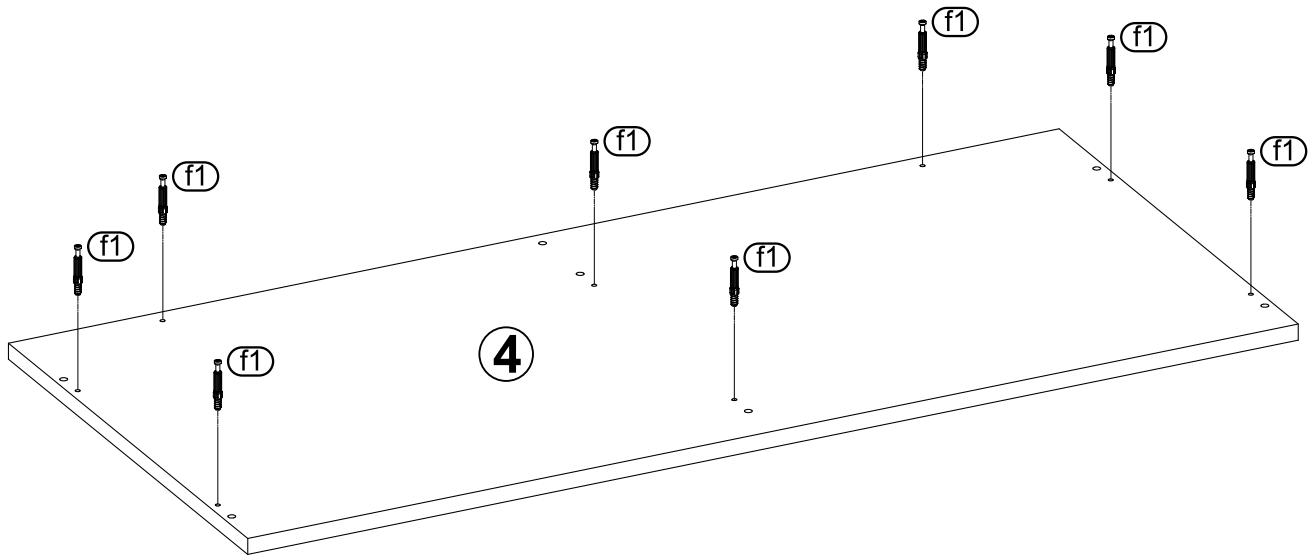
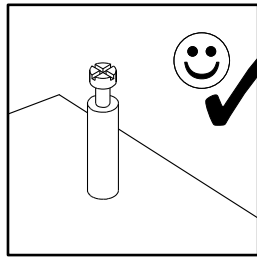
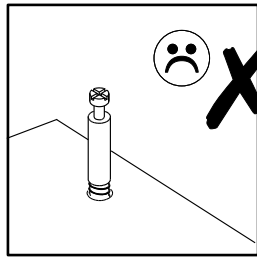
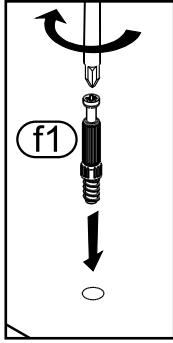

5

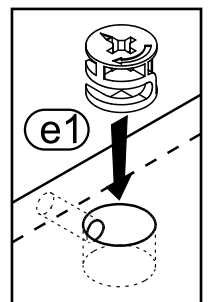
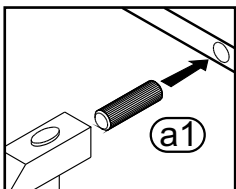
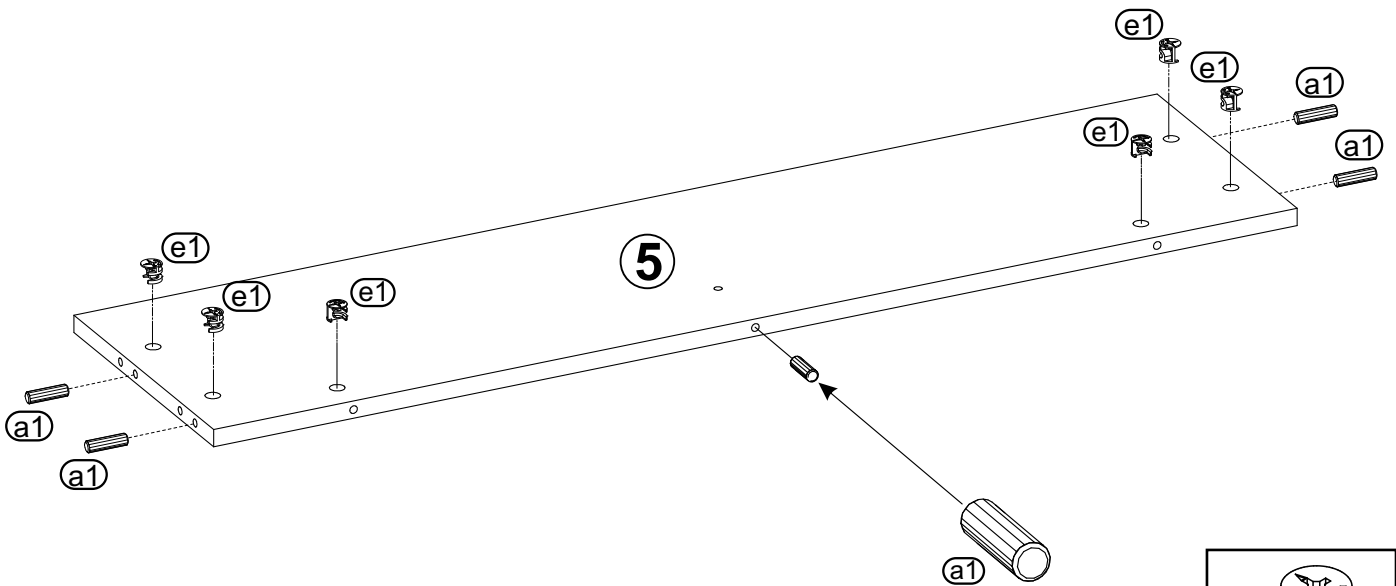

6

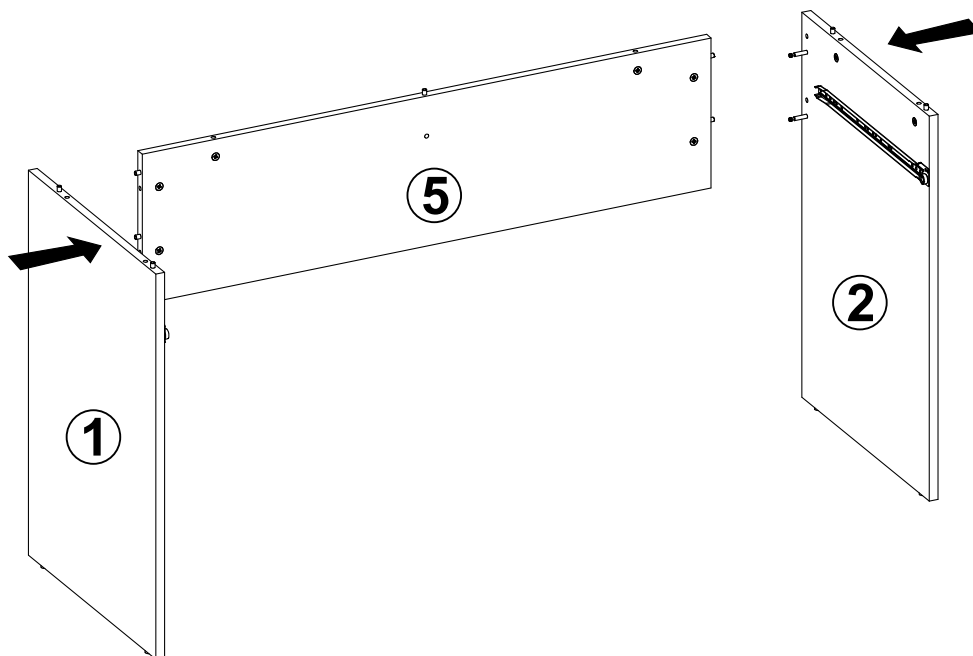
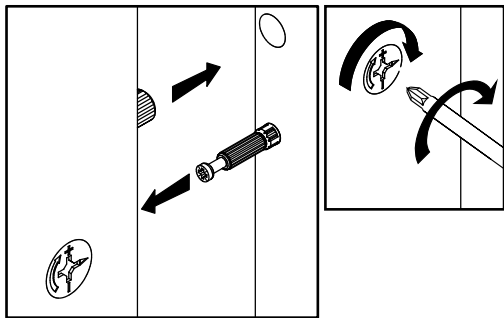

7

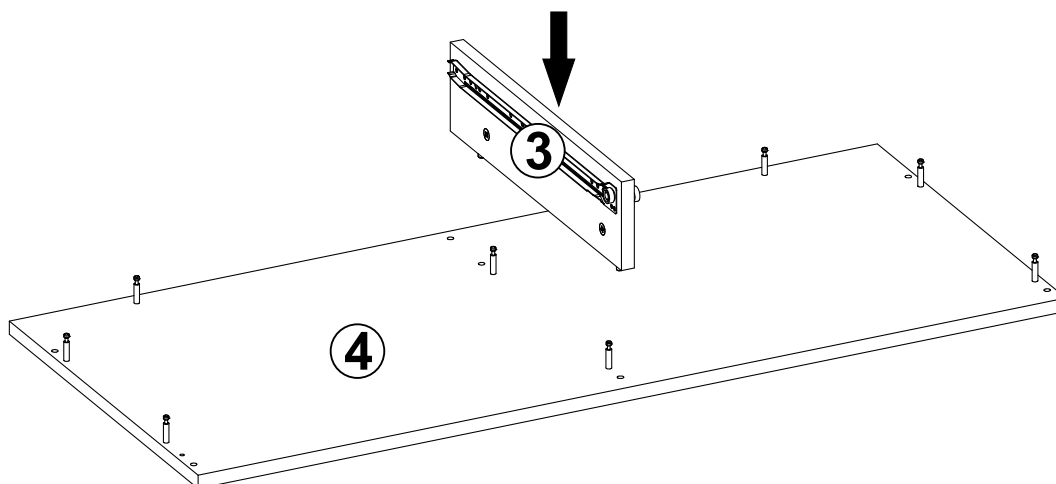
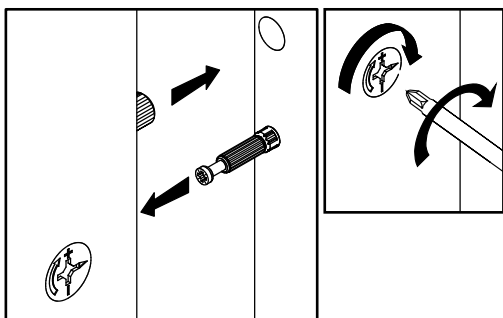

8

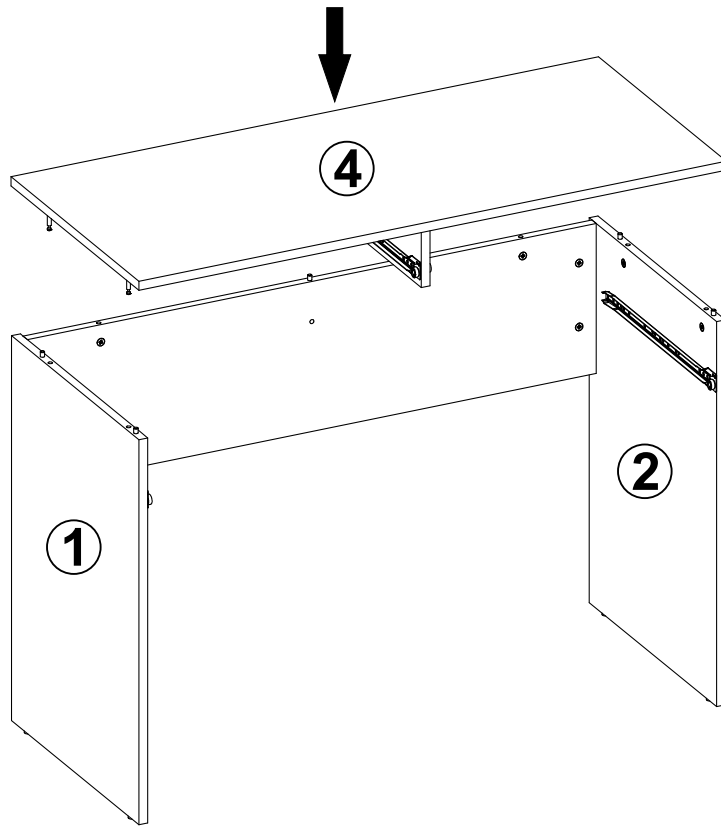
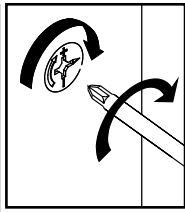
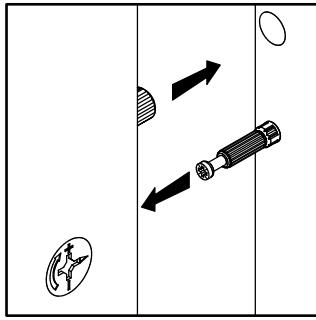

9

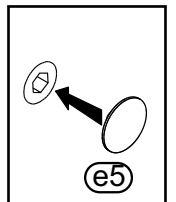
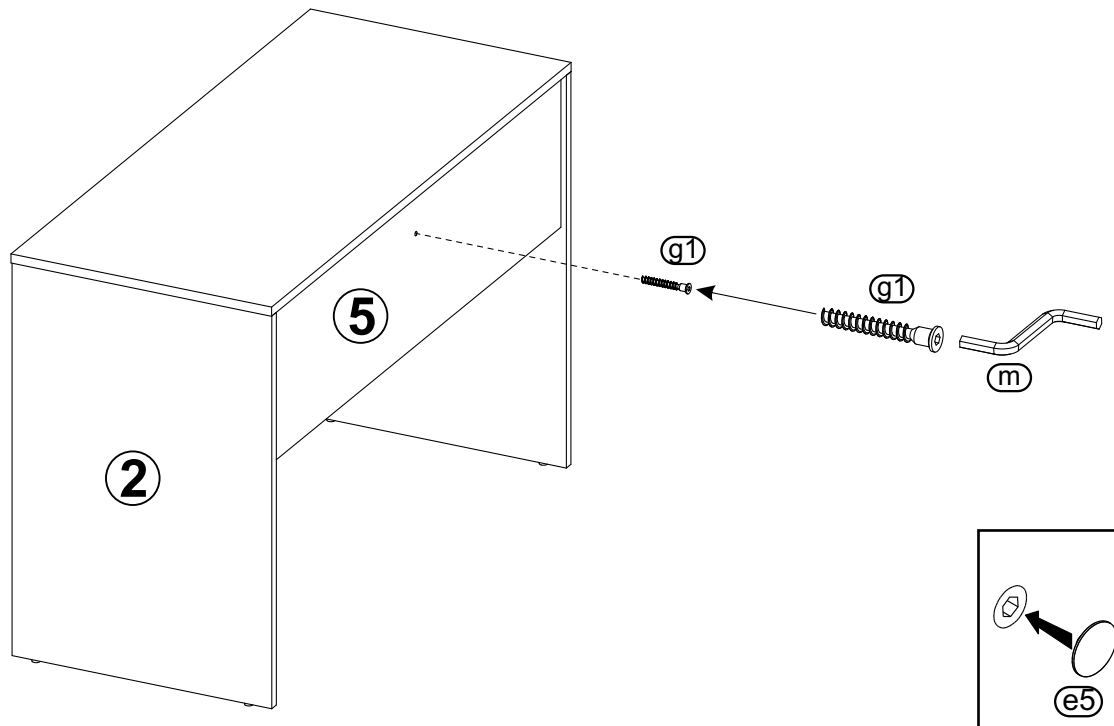

10



Zwróć szczególną uwagę na prawidłowe zamocowanie regulatora frontu.

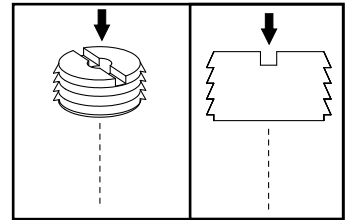
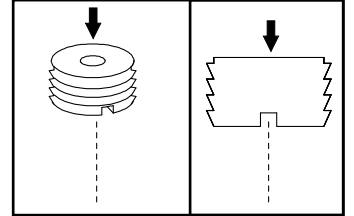
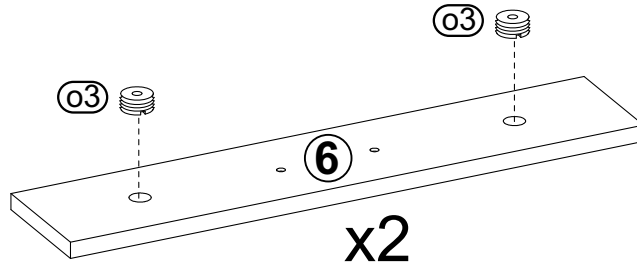
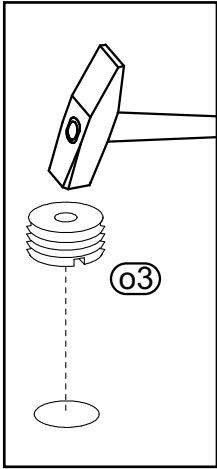

11

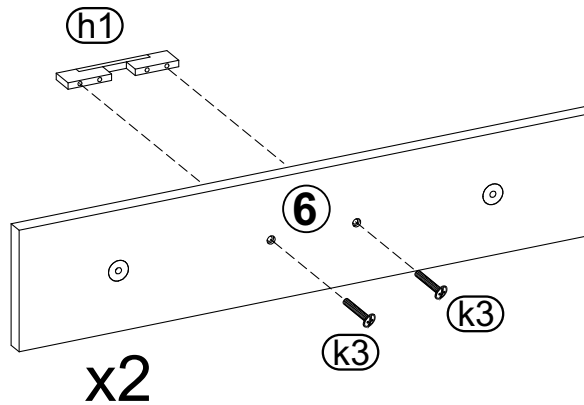
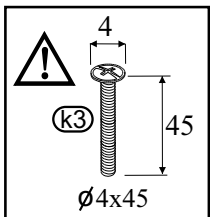

12

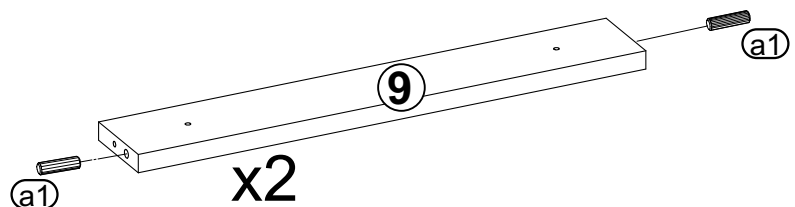
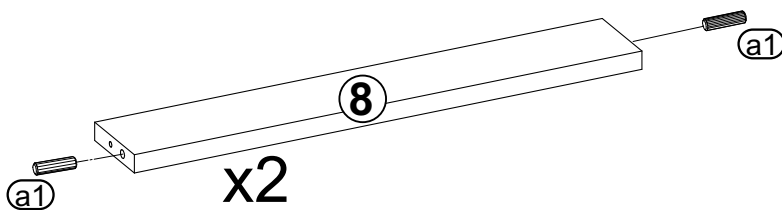

13

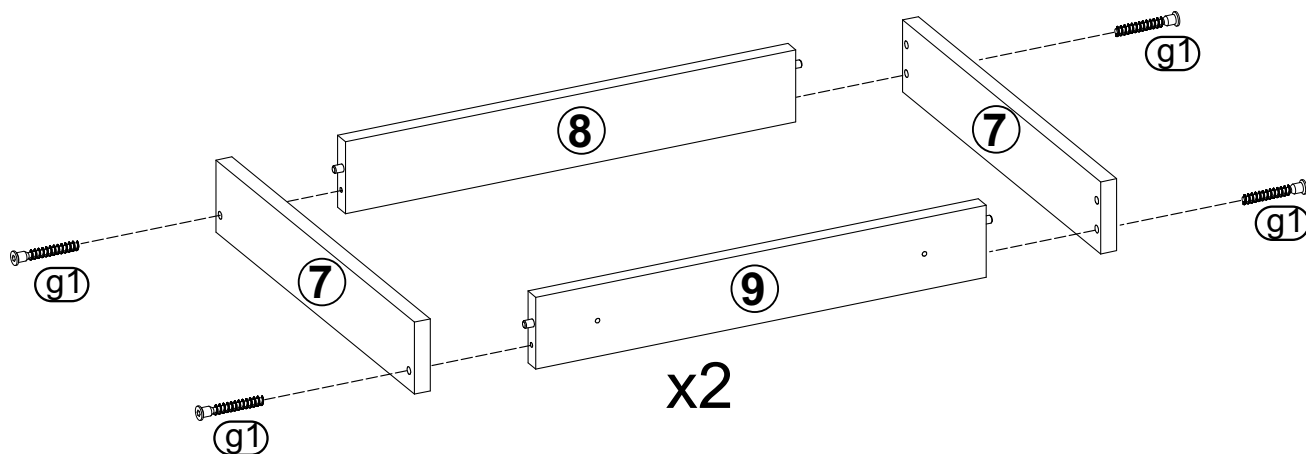

14

Uwaga !!!

Przed zamocowaniem dna szuflad należy zmierzyć przekątne szuflad. Jeżeli wymiary są jednakowe to możemy przystąpić do zamocowania ich, jeżeli nie to musimy do tego doprowadzić ściskając przeciwległe rogi szuflady, tam gdzie wymiar był większy.

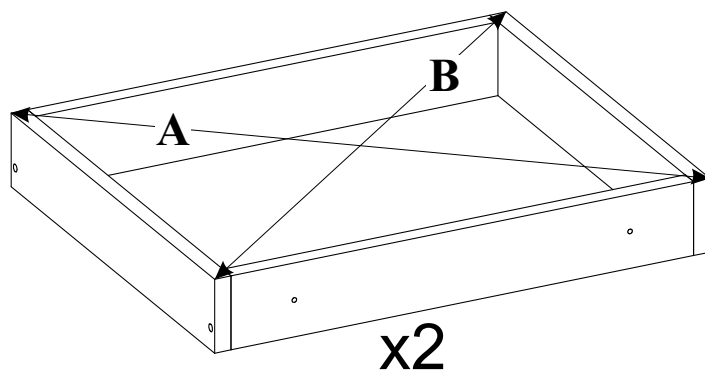

15

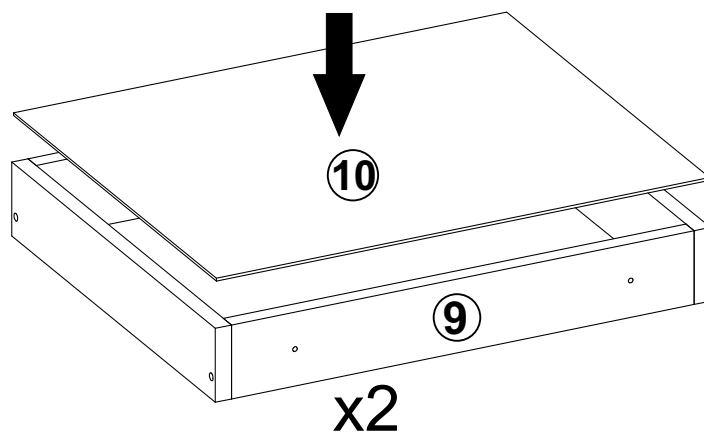

16

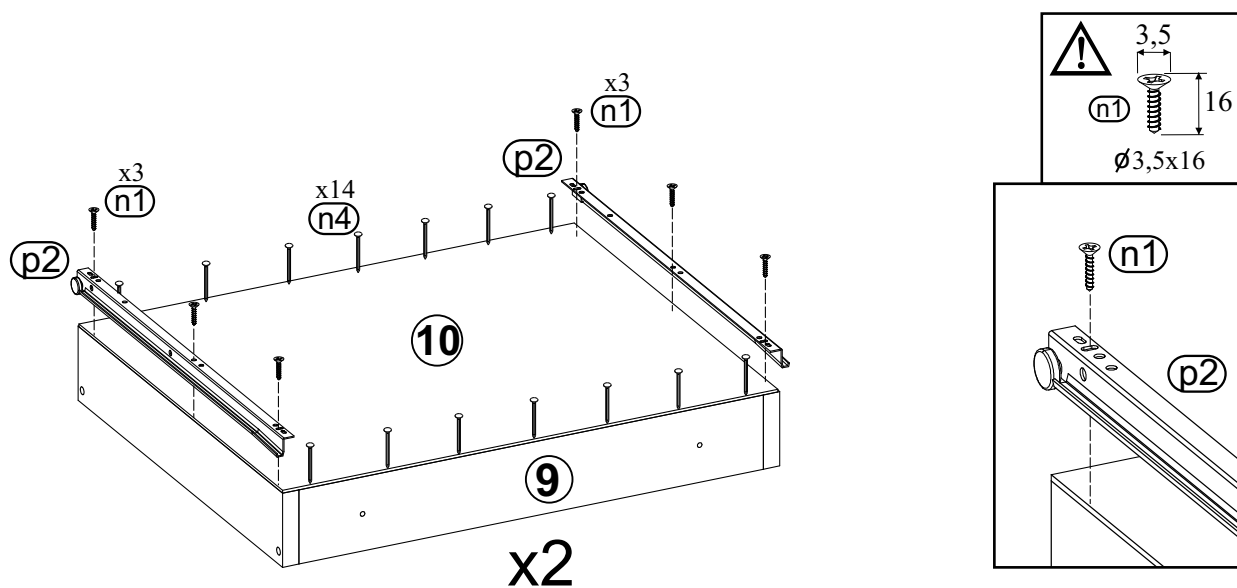

17

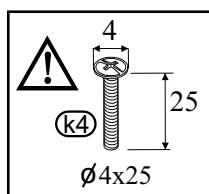

Uwaga
Przed całkowitym dokręceniem frontu możliwa jest jego regulacja.

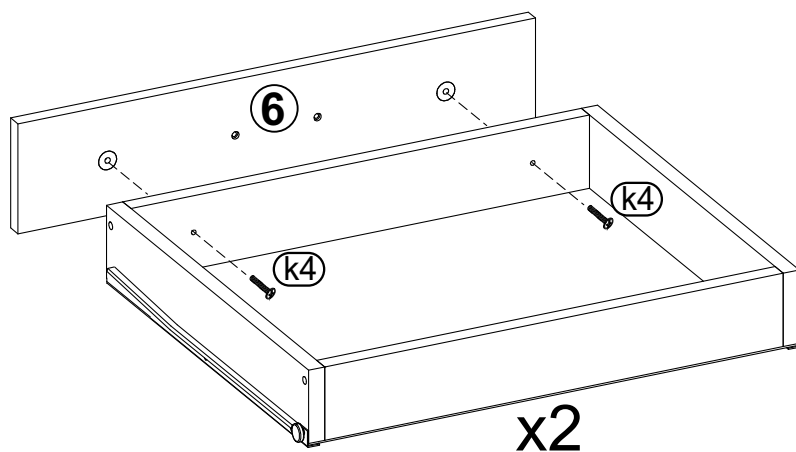
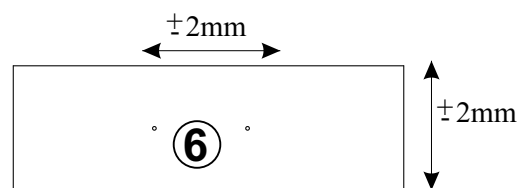

18

