

Model :

RENIA 8- (RE-8) -Witryna 2D

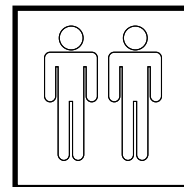
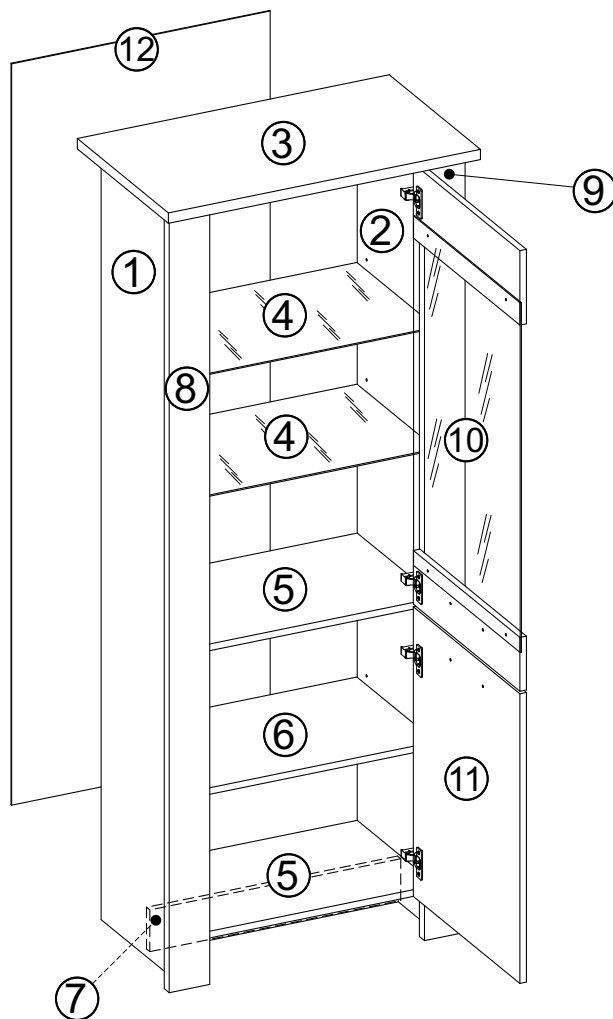
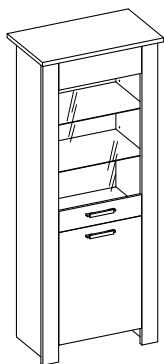

Przed przystąpieniem do montażu należy sprawdzić zawartość paczek pod względem ilości i jakości z instrukcją montażu.

NIE WOLNO montować uszkodzonych elementów mebli, ewentualne ich wady należy zgłosić przed montażem w przeciwnym razie nie będą one podlegały reklamacji.

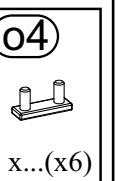
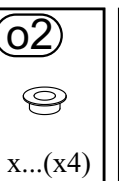
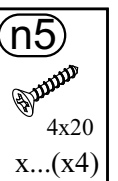
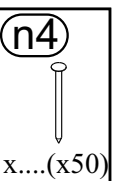
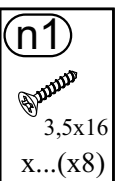
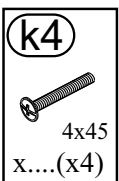
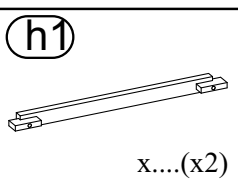
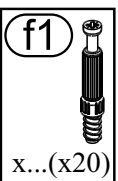
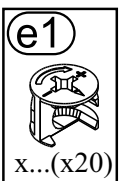
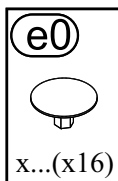
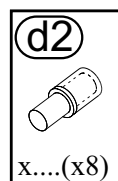
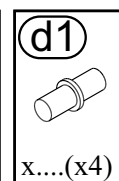
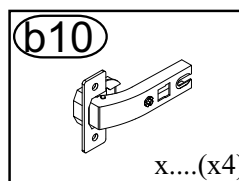
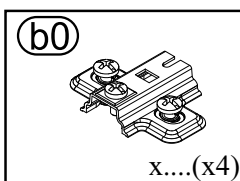
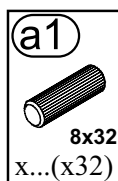

tel. 41 331 63 40,
fax.41 331 64 11
e-mail:biuro@k-f-m.pl
<http://www.kieleckafabrykamebli.pl/>

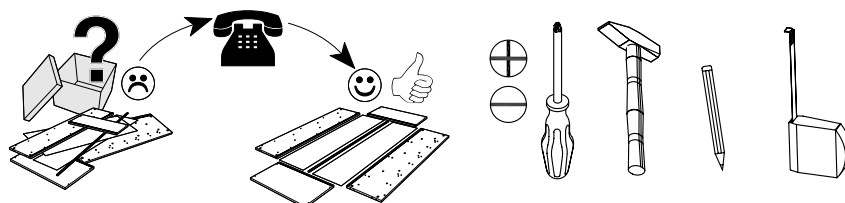

1

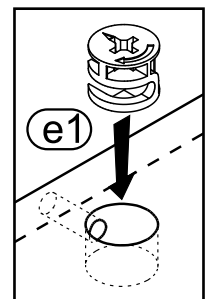
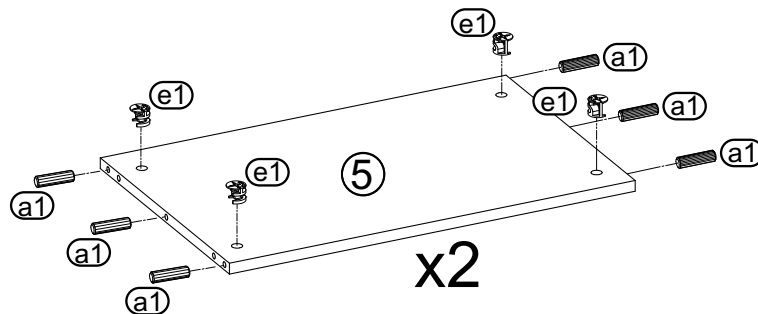
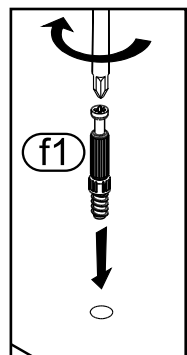
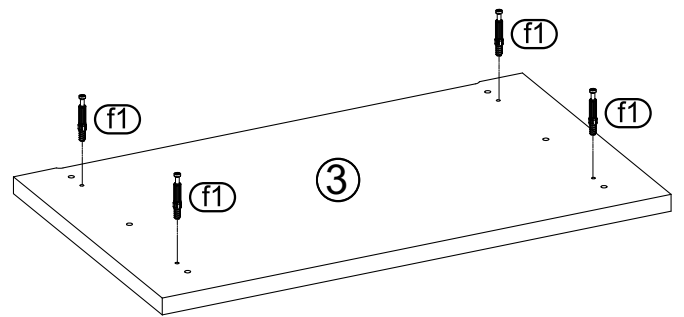
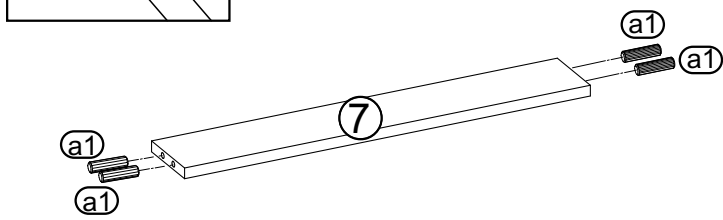
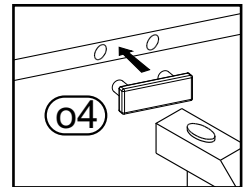
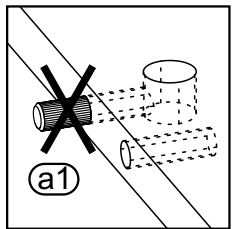
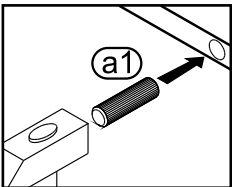
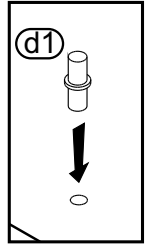
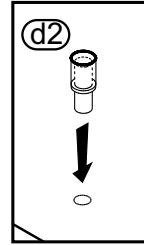
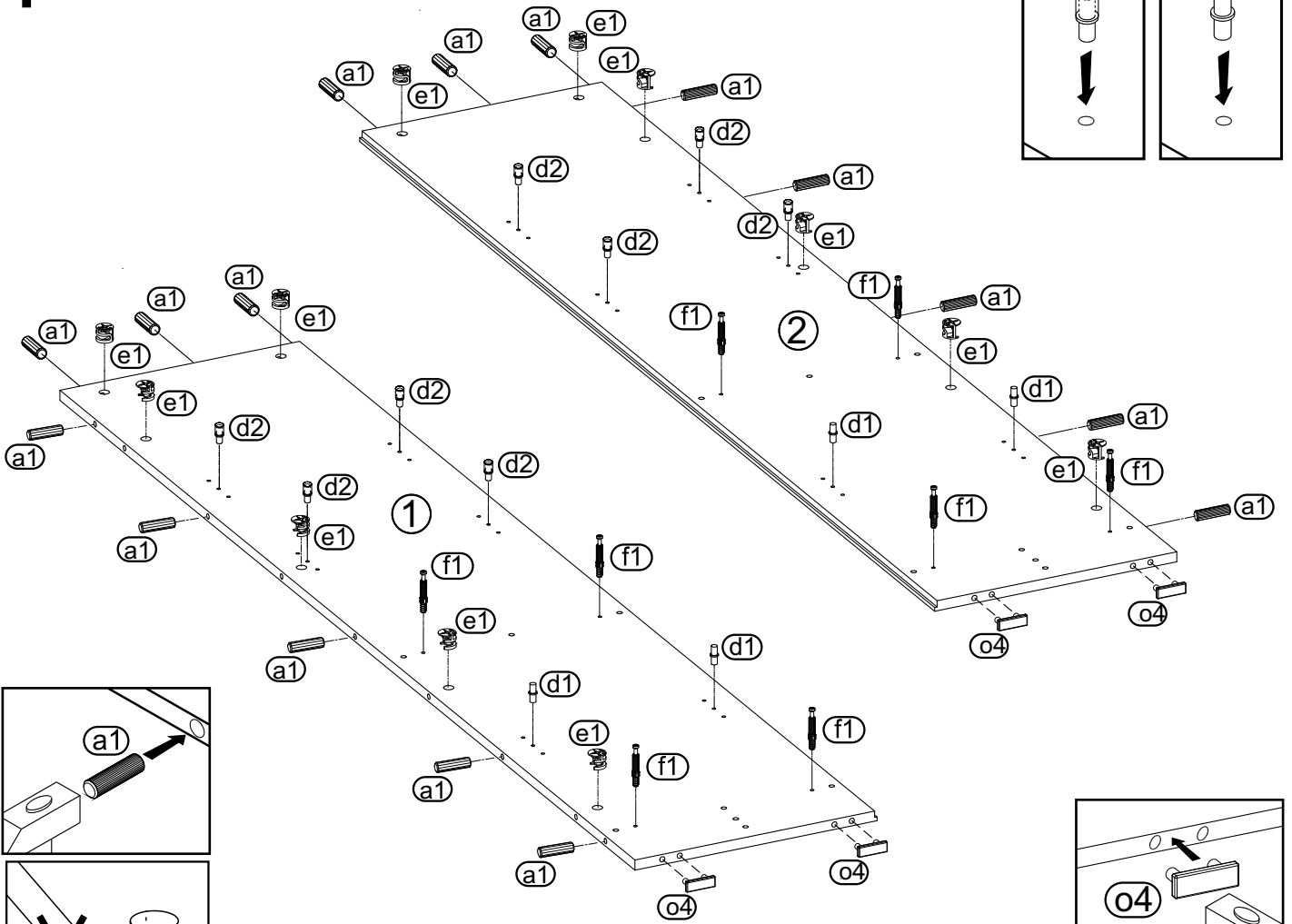

2

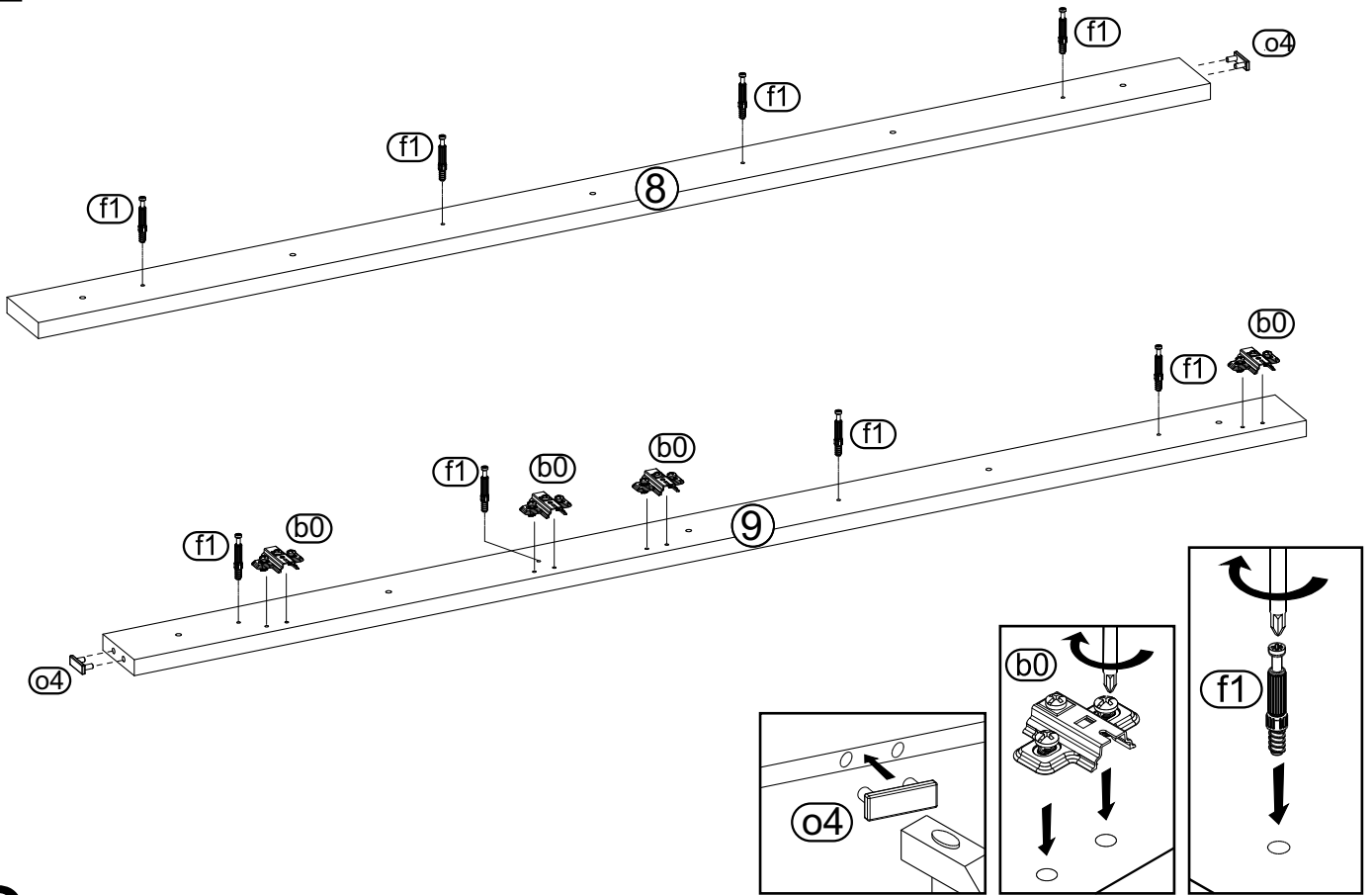

3

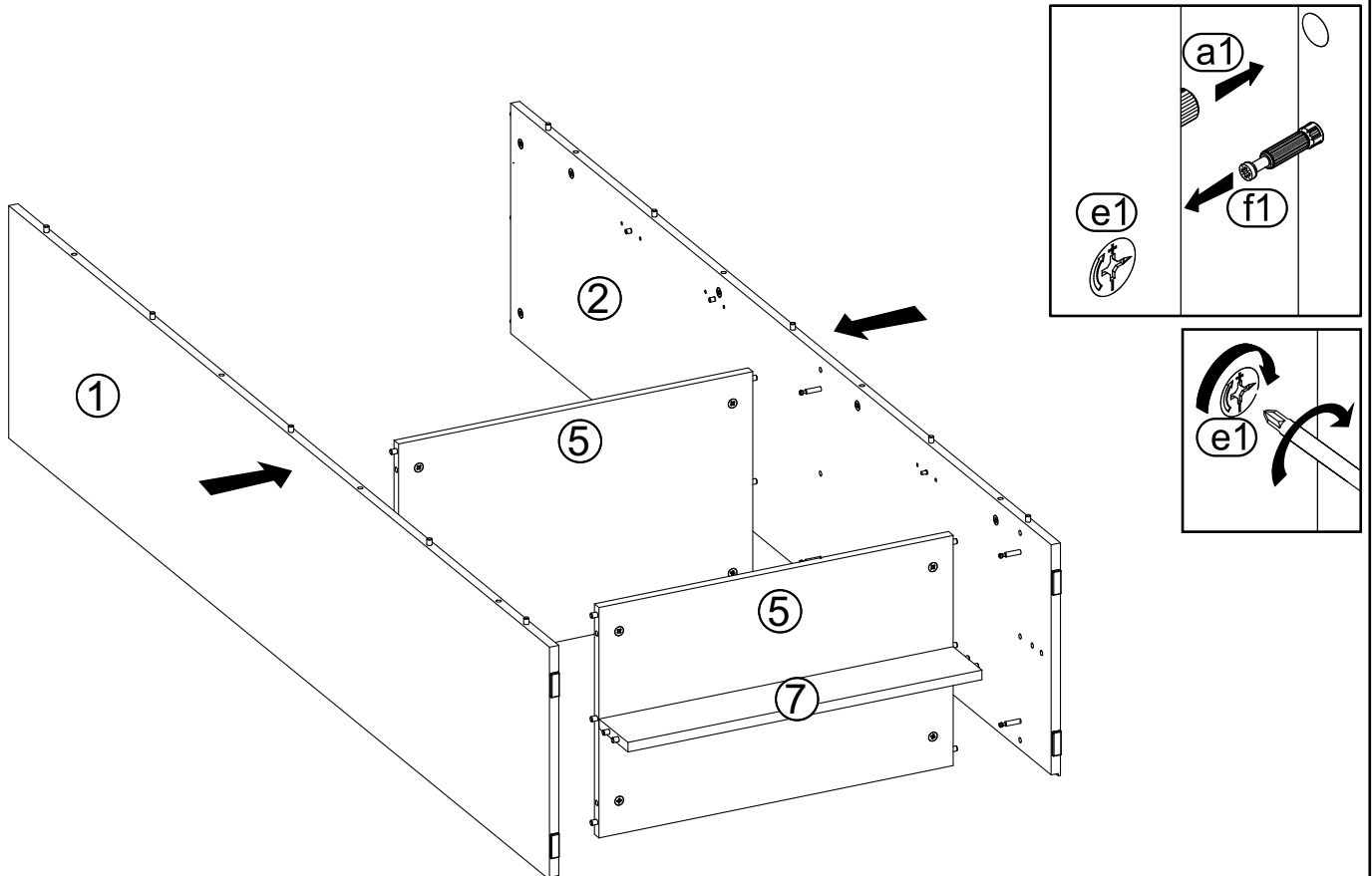

4

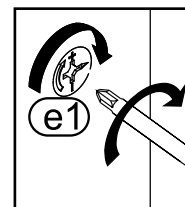
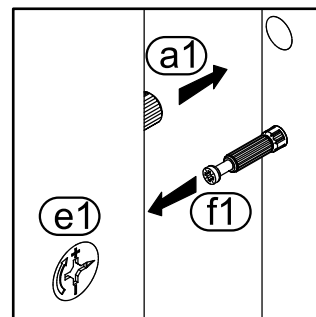
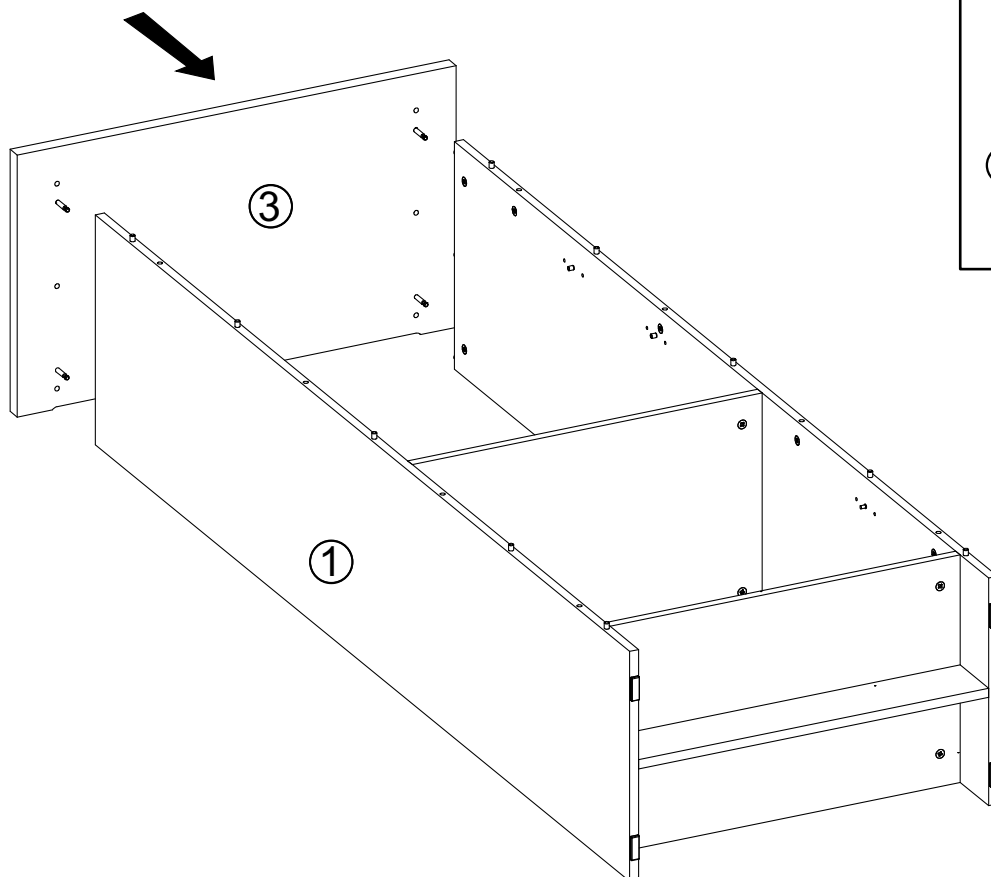

5

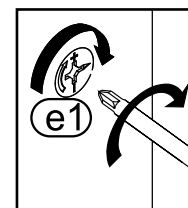
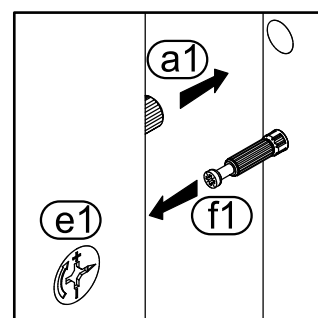
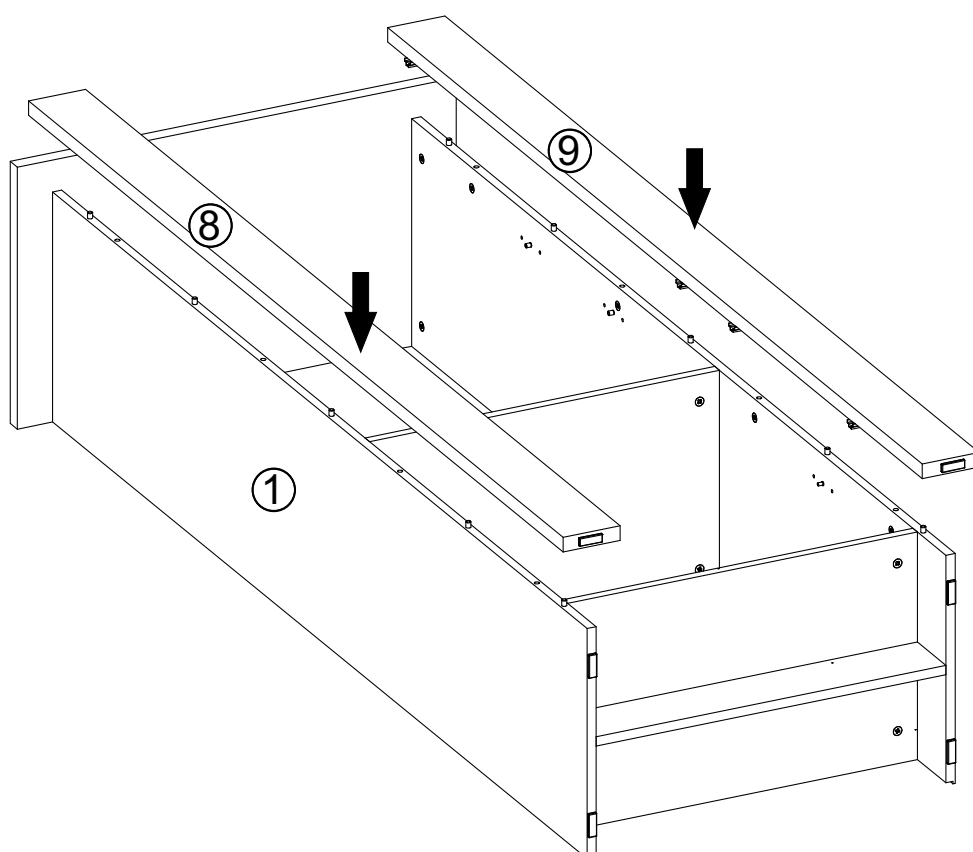

6

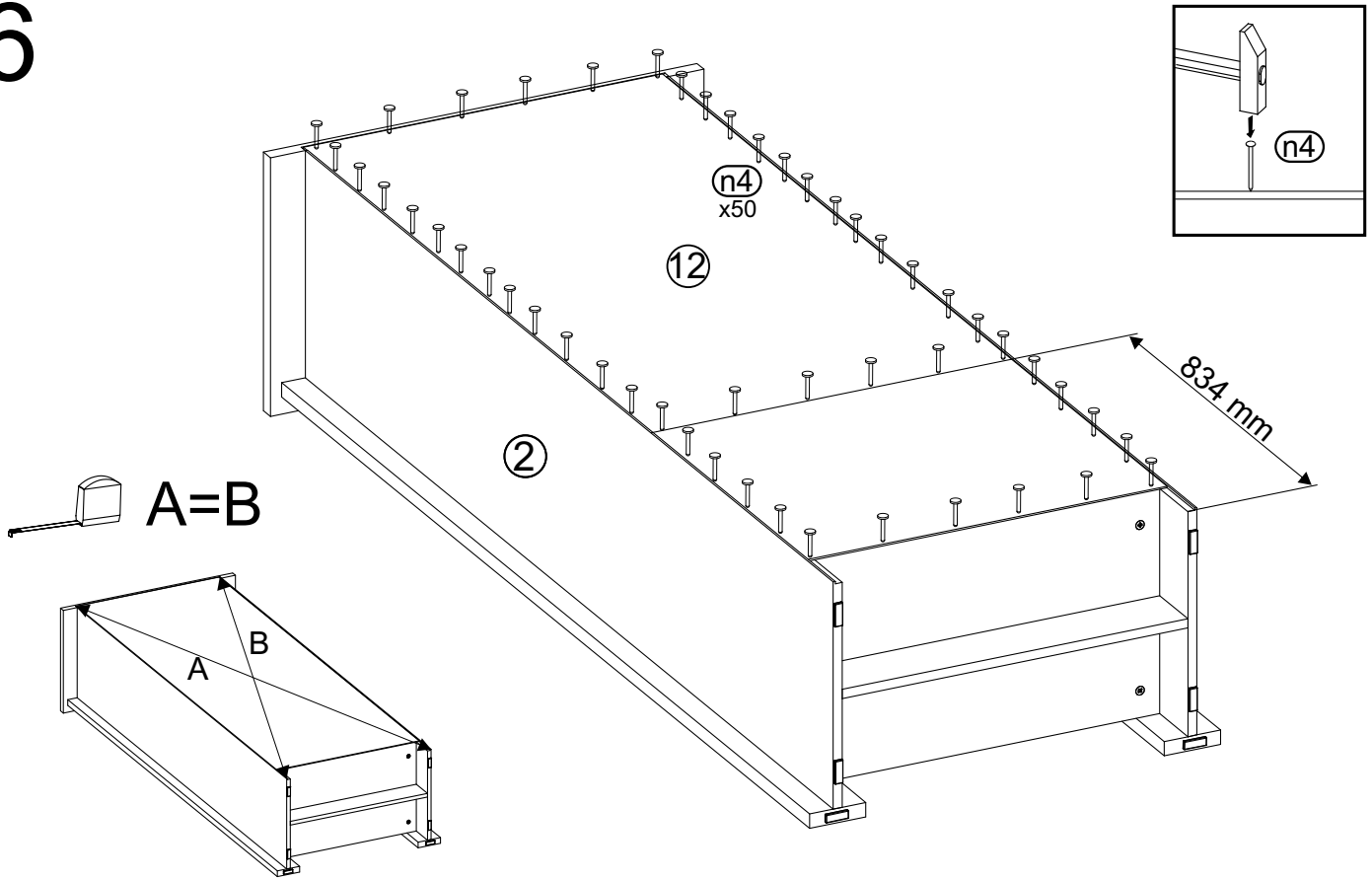

7

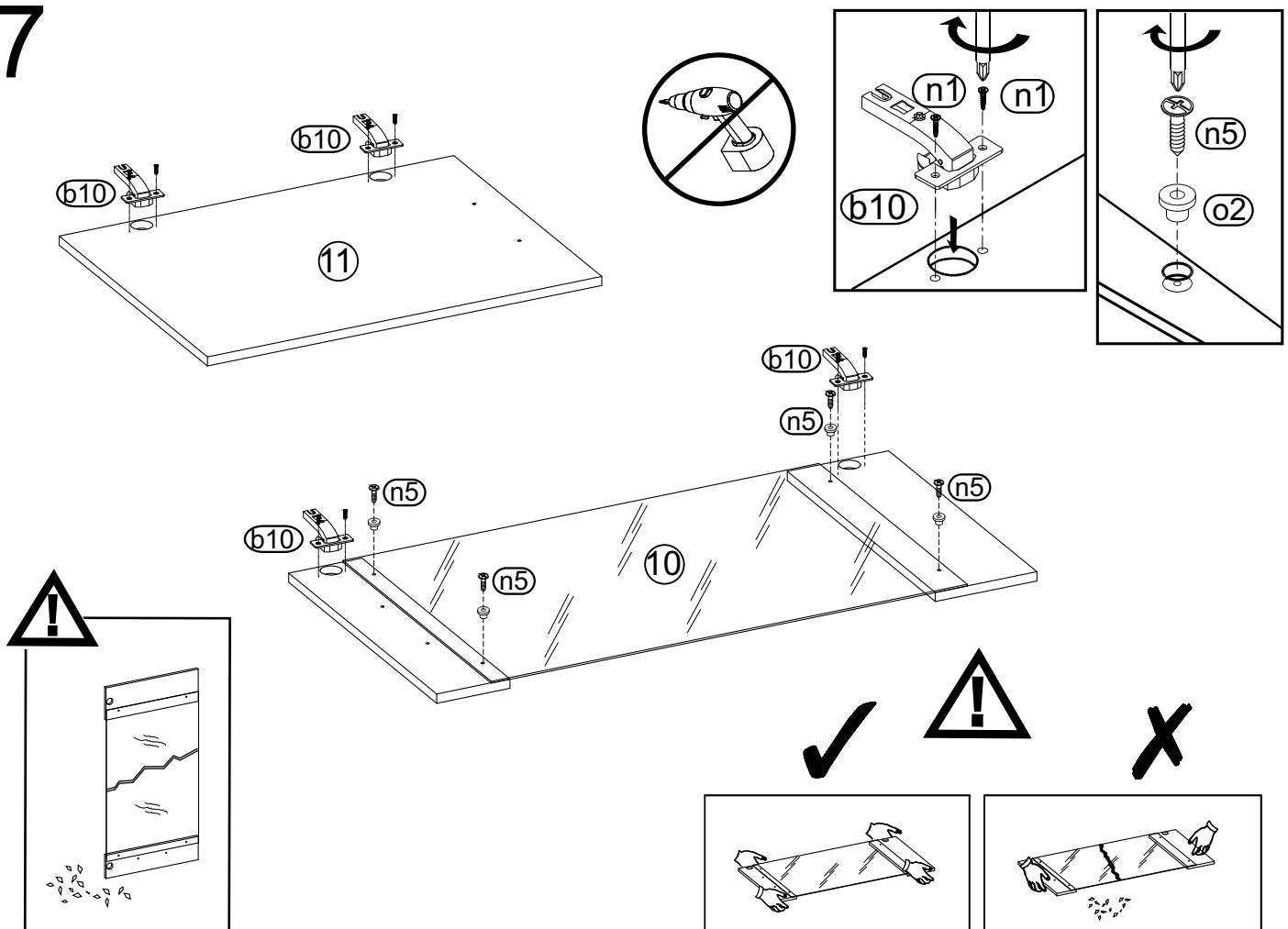

8

